



 Horse trailers / Hæstebengere



English

Norsk



FIRST CLASS TRANSPORT



Thank you!
Tusen takk!



We are very pleased about winning the CAVALLO readers' choice award (Germany's best known horse magazine) once again! This is the fifth time Böckmann has been chosen by thousands of survey participants as their favourite trailer brand. For the fifth time, the entire Böckmann team says: Thank you very much! For more information go to: www.boeckmann.com

Vi er svært glade for den nye utnevnelsen som vi har fått av CAVALLOs lesere (det meste kjente bestemagasinet i Tyskland)! For femte året i rad er Böckmann kåret til det mest populære bengermerket, i undersøkelsen med flere tusen deltakere. For femte gangen sier hele Böckmann-teamet: tusen takk! Les mer her: www.boeckmann.com

COMPANY DETAILS

Design & Realization: KAAPKE GmbH. All photographs were taken at the Böckmann yard in Lastrup. This horse trailer catalogue is valid from the 2/2019 until revoked.

REDAKSJON

Idé & formgivning: KAAPKE GmbH. Alle bildene ble tatt i Böckmann-stallen i Lastrup. Denne bestebengerkatalogen gjelder f. o. m. 2/2019 og til annet meddeles.



🇬🇧 CONTENT AT A GLANCE.

BÖCKMANN – THE FAMILY BUSINESS

From family tradition to success	3
• The way we work: By practitioners for practitioners	4
Milestones since 1956.....	5

BÖCKMANN'S ADDED VALUES

Maintains its value.....	7
• Good for your horse	8 – 9
• Good for you	10 – 11

OUR DESIGN FAMILIES

Your product finder	12 – 13
The Esprit silver+black models 🐎 - 🐎 🐎 14 – 21	
The Uno & Duo family 🐎 - 🐎 🐎 22 – 27	
The Champion & Comfort family 🐎 🐎 28 – 33	
The Master family 🐎 🐎 34 – 39	
• The Portax family 🐎 🐎 40 – 55	
The Traveller family 🐎 🐎 - 🐎 🐎 🐎 56 – 61	

ORIGINAL BÖCKMANN ACCESSORIES

Model types (Carriage, Western, Pony, Iceland Ponies)...	64 – 65
• Accessories	66 – 68
Böckmann collection	69
Colours	70
Decors	71

WORLD OF BÖCKMANN

• Böckmann Horse Trucks	72
Böckmann Professional Trailers	73
• Böckmann Horses	73

• In these chapters, you'll find QR codes for interesting videos!

🇳🇴 OVERSIKT OVER INNHOLDET.

BÖCKMANN – FAMILIEBEDRIFTEN

Fra familietradisjon til suksess.....	3
• Vår arbeidsmåte: Utviklet for å dekke dine behov	4
Milepæler siden 1956.....	5

FORDELENE MED BÖCKMANN

Bra for verdistabiliteten	7
• Bra for besten din	8 – 9
• Bra for deg	10 – 11

VÅRE DESIGNFAMILIER

Produktsøker	12 – 13
Esprit-modellene silver+black 🐎 - 🐎 🐎 14 – 21	
Uno & Duo-familien 🐎 - 🐎 🐎 22 – 27	
Champion & Comfort-familien 🐎 🐎 28 – 33	
Master-familien 🐎 🐎 34 – 39	
• Portax-familien 🐎 🐎 40 – 55	
Traveller-familien 🐎 🐎 - 🐎 🐎 🐎 56 – 61	

ORIGINALT BÖCKMANN-TILBEHØR

Modellutførelser (Vogn, Western, Pony, Islandsbest)	64 – 65
• Tilbehørsprogram	66 – 68
Böckmann-kolleksjonen	69
Farger	70
Dekorasjon	71

WORLD OF BÖCKMANN

• Böckmann Horse Trucks	72
Böckmann proffhengere.....	73
• Böckmann hester	73

• I disse kapitlene finner du koder for interessante videoer!

🇬🇧 Discover MORE DETAILS.

See the fascinating video clips to discover the added values offered by Böckmann: Simply scan the QR codes in this catalogue with your smartphone to see the additional information.

(You may need an app for scanning the codes.)



🇳🇴 Oppdag mer, GANSKE ENKELT.

Opplev Böckmann-merverdien i informasjonsrike videoklipp: Skann ganske enkelt QR-kodene i denne katalogen for å vise dem.

(Eventuelt kreves en app for å skanne kodene)



YouTube All videos are also available in our YouTube channel:

Alle filmene finnes også i vår kanal: www.boeckmann.com/youtube
Scan the QR code now and have a look. Skann QR-koden nå og se på innholdet.

🇬🇧 From family tradition to success.

“You have to put your heart into the business to be successful in the long run.” This is the philosophy that Anton Böckmann taught his four sons at an early age. As the village blacksmith he lived and maintained the good, old craft tradition – and family life. His four sons Gilbert, Tönne, Klaus and Roger still remember this well to this day, particularly the Sundays, which were always dedicated to the family. These days had a recurring ritual: After church, father Anton Böckmann put his children on the family’s own ponies.

The father filled his children with enthusiasm for horses and riding – and went on to do everything in his power to support his children’s hobby.

As the children grew older, the ponies had to be transported to riding events. This prompted Anton Böckmann to design his first pony trailer. The foundations for Böckmann Fahrzeugwerke GmbH were laid.

And when his sons grew out of their little ponies, father Böckmann decided to build his own horse trailer. Just a short while later the first trailers were sold. Serial production started back in the 60s. This way, Anton Böckmann not only made a virtue out of necessity, but also a career out of virtue!

The third generation is also sporty, successful and already has a firm grip on the reins.



Not forgotten: The four Böckmann brothers as children with their first Shetland pony “Raudi”.
Uforglemmelig: De fire Böckmann-brødrene på sin første shetlandsponny “Raudi” i barnehagen.



Klaus Böckmann: Practical testing with his horses.
Klaus Böckmann: Praksistest med bestene sine.



Trainer Gilbert Böckmann
Trener Gilbert Böckmann

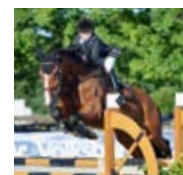

Already with a firm grip on the reins – the third generation of the Böckmann family (left to right Liam, Jason, Calvin and Leonie-Celine Böckmann).
Sitter allerede godt i sadelen: tredje generasjon i familien Böckmann (fra venstre mot høyre Liam, Jason, Calvin og Leonie-Celine Böckmann).

🇳🇴 Fra familietradisjon til suksess.

“Det er bare de som satser helhjertet som har langsiktig suksess.” Dette livsmottoet ga Anton Böckmann tidlig videre til sine egne sønner. Som landsbysmed levde og pleiet han de gode, gamle håndverkstradisjonene og knyttet det til det familiære. De fire sønnene Gilbert, Tönne, Klaus og Roger husker det fremdeles som det var i går. Det var spesielt søndagene som sto i familiens tegn. Disse dagene var preget av et ritual som gjentok seg: Etter gudstjenesten satt far Anton Böckmann barna sine på familiens ponnier.

Sønnene ble smittet av farens begeistring for hester og ridning og han gjorde alt for å støtte barnas hobby. Da barna ble eldre måtte ponnierne f. eks. transporteres til små konkurranser. Det var da Anton Böckmann konstruerte sin første ponnibenger. Grunnsteinen for Böckmann Fahrzeugwerke GmbH var lagt.

Straks sønnene vokste fra de små ponnierne, begynte faren å bygge den første hestehengeren. Etter kort tid ble de første hengerne solgt. Allerede på 60-tallet startet serieproduksjonen. Sett fra dette synspunktet har Anton Böckmanns egne behov og interesser banet vei for det som skulle bli hans yrke!

Den tredje generasjonen har også sportslig suksess og sitter godt i sadelen.

🇬🇧 The way we work: By practitioners for practitioners.

The Böckmann sons didn't just inherit their father's passion for horses. They also continued to run the company successfully. Today, the Böckmann Group employs more than 450 people. To this day the vehicle factory has produced more than 800000 trailers – and delivered them to customers worldwide. Beside from the trailer business the whole family is as diligent with its Pferde GmbH and is focussing on horse breeding and their training and competition yard.

There is one thing that all of the company's divisions have in common: a passion for horses. Daily life with their own horses has led to numerous product developments that all focus on the horses' needs. And things will stay this way in future. This is the Böckmann family's commitment – for whom, as we know, horses have always been part of the family.



The origin of the Company: The passion for horses.
Firmaets opprinnelse: Begeistring for hester.



Böckmann Pferde GmbH
Firmaet Böckmann Pferde GmbH



A large family; from a small blacksmith's workshop to the Böckmann Group – with a workforce of over 450 in 2019.
En stor familie: fra å være en liten smie til å bli Böckmann-gruppen med over 450 ansatte i 2019.

🇳🇴 Vår arbeidsmåte: Utviklet for å dekke dine behov.

Sønnene til Böckmann har ikke bare arvet lidenskapen for hester av faren sin. De fører firmaet videre med stor suksess. I dag er det over 450 ansatte i Böckmann-gruppen. Hittil har kjøretøysfabrikkene produsert mer enn 800 000 tilhengere og levert dem til kunder over hele verden. I tillegg til tilhengerdelen er hele familien involvert i bestefirmaet som konsentrerer seg om besteoppdrett og trenings- og turneringsstallen.

Dette har alle delene av firmaet felles: Lidenskapen for hester. Det daglige arbeidet med egne hester førte til tallrike produktutviklinger, som alle var konsentrert rundt hesters behov. Og slik vil det også bli i fremtiden. Hele familien ser på det som en forpliktelse, da hester alltid var en del av familien.



See a video of the Böckmann history:
Scan the code now!
Opplev historier fra Böckmann på video:
Skann koden nå!



Böckmann Fahrzeugwerke GmbH
Firmaet Böckmann Fahrzeugwerke GmbH

🇬🇧 Milestones since 1956.

Innovation as a (family) tradition: The trailers have been improved all the time because the family use their trailers themselves. This is how Böckmann became the market leader for horse trailers – and one of the leading European trailer brands. All these developments have one thing in common: a product needs to be good enough to meet the requirements of the family and their horses before it enters serial production. Thus, Böckmann have exactly the same aim as the rest of the riding community: the well-being of the horse!



1956

Foundation of the original company, a blacksmith and agricultural equipment repairs business.

Opprettelse av hovedfirmaet for hoveslag og reparasjon av landbruksmaskiner.



1963

A comfortable ride and wind protection: a trailer covered with a canvas tarpaulin.

Høy kjørekomfort og vindbeskyttelse: En lukket hette med seildukpresenning.



1971

Serial production starts after the move to the Lastrup industrial estate.

Med flyttingen fra Lastrup indistriområde startet serieproduksjonen.



1990

The standard for horse trailers: the Böckmann panic system.

Standarden ang. bygging av hestehengere: Böckmanns panikkssystem.

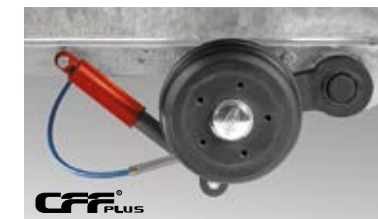

2003

Introduction of a new lowered comfort suspension chassis "CFFplus".

Innføring av det nye senkede Comfort-fjærings-understellet "CFFplus".



2009

Gilbert Böckmann's 3rd place at the Rider's Tour with No Father's Girl.

Gilbert Böckmanns gikk inn til 3. plass ved Rider's Tour med No Father's Girl.

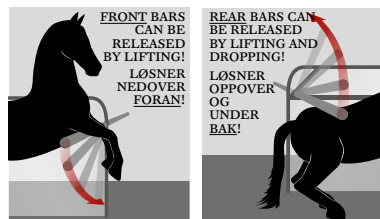

2011

The safety revolution in the world of horse trailers: the new Multi Safe System (MSS).

Sikkerhetsrevolusjon innen bygging av hestehengere: Det nye Multi Safe System (MSS).



2016

60-year anniversary: from the blacksmith's shop in Southern Oldenburg to "first-class trailers".

60-års jubileum: Fra "landsbysmie" til "tilbenger av første klasse".



2017

The new Portax L offers plenty of space for horse and rider. By the way: The new Portax L models received the 2016 Innovation Award of "Pferd & Jagd". Den nye Portax L modellen bar romslag plass for best og rytter. Den nye Portax L modellen ble tildelt Innovasjonsprisen fra Pferd & Jagd 2016.



2019

The new Grand Master and Big Master L offer plenty of space for horse and rider and shine with their distinctive design. Nye Grand Master og Big Master L tilbyr best og rytter mye plass, og kjennetegnes av unik design.

🇬🇧 More than a standard: Böckmann's added values.

🇳🇴 *Mer enn standard: Fordelene med Böckmann.*



🇬🇧 Maintains its value.

Original Böckmann quality in every detail. – What this means for you is: durability and excellent trade-in value. We achieve this by using only highest quality materials and solid workmanship throughout. Find out for yourself!

🇳🇴 Bra for verdistabiliteten.

Original Böckmann-kvalitet ned i minste detalj. – For deg betyr det: Lang levetid og en spesielt høy salgsverdi ved videresalg. Dette oppnås ved bruk av høyverdig materialer og en solid bearbeidelse. Overbevis deg selv!

1. Chassis / Chassis

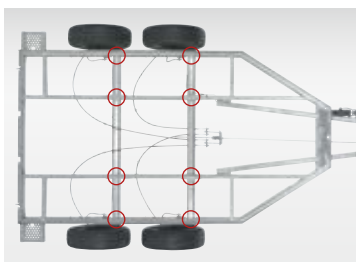

Made for heavy loads with axles bolted 8x to the longitudinal beam construction and a welded, hot-galvanised steel frame

Laget for høy belastning ved aksene som er skrudd fast til lengdedragerkonstruksjonen på 8 steder og sveisete, ildforsinkete stålrammer



Stable frame thanks to Z-section frame of galvanised special steel throughout – firmly bolted onto the structure

Stabile rammer grunnet de gjennomgående z-profilrammene som er laget i ildforsinket spesialstål og som er skrudd fast i overbygget

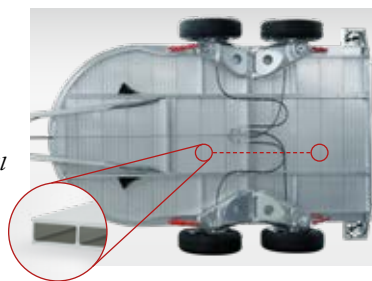

Maintains its value. / Bra for verdistabiliteten.

Robust and rot-proof thanks to quality solid aluminium floor (option in some cases*); reinforced with a closed profile in the stall area

Robust og rustfri grunnet kvalitets-beluminiumsgulv (delvis tilbehør); forsterket ved en lukket profil i ståområdet*

2. Structure / Ytre oppbygging



Stable polyester cover thanks to aluminium top support sections bolted with stainless steel bolts

Stabil polyesterbette med omløpende aluminiumsbetteholderprofil som er skrudd fast med V2A-edelstålsskruer

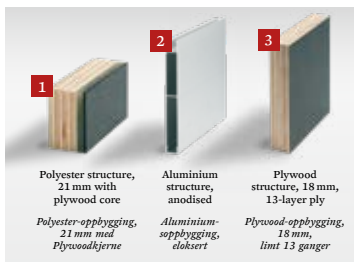

Quality and stability thanks to polyester sandwich-type construction (1), aluminium twin-web sections (2) or adhesion bonded quality plywood (3)
Kvalitet og stabilitet ved hjelp av polyester-sandwich-konstruksjon (1), aluminium-doppelstegprofiler (2) eller limt kvalitetsplywood (3)



Maintains its value. / Bra for verdistabiliteten.

Stable structure thanks to overlapping corner unions and galvanised, lateral, steel struts made of solid M sections
Stabil oppbygging ved hjelp av overlappende hjørnetilskruinger og ildforsinkete stålsidebjelker i massivt M-profil

3. Interior / Utstyr innvendig



Stable divider wall construction thanks to solid, welded steel frame

Stabil skilleveggkonstruksjon med massive, sveisete stålrammer



Resilient thanks to adhesion bonding and sealing of rubber flooring throughout
Gummigulvet som er fullstendig fastlimt og forseglet gir god motstandsdyktighet



Maintains its value. / Bra for verdistabiliteten.

Kick protection thanks to high impact-resistant synthetic material of side walls (option in some cases*)
Sparkebeskyttelse ved et spesielt slagfast kunststoff på sideveggene (delvis tilbehør)*

🇬🇧 Good for your horse.

From the loading height through to the Multi Safe System (MSS): The following features (all of which are included as standard) were developed as a result of the experiences travelling with our own horses and adapted to meet their needs and guarantee their comfort and well-being!

🇳🇴 Bra for hesten din.

Fra lastehøyden til det Multi Safe System (MSS): Detaljløsningene nedenfor (alle seriemessige) ble utviklet gjennom erfaringen med egne hester og konsekvent tilpasset deres behov. Slik føler hesten din seg helt vel!

1. Loading and Unloading / Laste og losse bestene



Easier access for the horse as a result of the lowered comfort suspension chassis "CFFplus"
Det senkede Komfort-fjærings-understellet "CFFplus" gir lavere lastehøyde



A maximum of space due to narrow cover edges and tarpaulin lift installed on the inside
De smale bettekantene og den innvendige rullgardinen gir en stor gjennomgang



No slipping because of the special cross step bars and side stops on the rear ramp covering
Spesialverrtrinnlister og sidestopp på baklebelegget gir optimalt feste

Good for your horse. / Bra for hesten din.

2. Interior / Innvendig

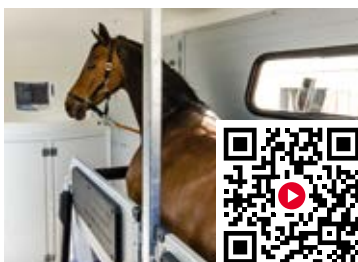

Plenty of headroom thanks to the generous dimensions of all Böckmann models
Det frie romkonseptet gir stor hodefrihet i alle Böckmann-modellene



A firm foothold due to rubber matting with anti-slip structure
Gummigulvet med sklisikker tekstilstruktur gir sikkerhet



Plenty of space for the tail because of the generous amount of space between the breast bar and the tail gate
Den store avstanden mellom bommen og baklemmen gir halen god plass

Good for your horse. / Bra for hesten din.

3. Driving Comfort / Kjørekomfort



Optimum road holding due to the lowered comfort suspension chassis* with wheel shock absorbers and soft suspension
Det lavtliggende komfort-fjærings-chassiset med hjulstøtdempere gir optimalt veigrep og myk fjæring*



Even more comfort on the road with the world-class chassis* with galvanised independent wheel suspension, coil spring suspension and wheel shock absorbers
Enda mer kjørekomfort grunnet World-Class-chassiset med ildforsinket enkelthjuloppheng, skruefjæring og hjulstøtdempere*



Optimum interior atmosphere thanks to tarpaulin lift with integrated net** and Velcro fasteners (also protects against rain and cold)
*Optimalt romklima ved hjelp av rullgardinen med integrert nett** med borelåser (beskytter mot regn og kulde)*

Good for your horse. / Bra for hesten din.

4. Multi Safe System*** (MSS) / Multi Safe System*** (MSS)

Good for your horse. / Bra for hesten din.



Quick release system as the front breast bars can be opened by lifting them, the rear bars both by lifting and dropping them
 Bommene gir rask frigjøring. De kan utløses nedover foran og oppover og nedover bak

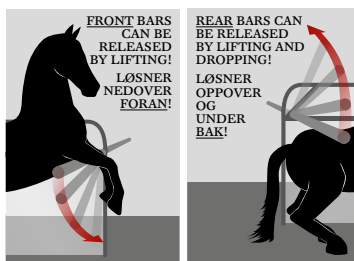

Extra safety as breast bars can be released from the front and rear (panic system front and rear)
 Mer sikkerhet ved bommene som kan utløses både foran og bak (panikk-systemet foran og bak)

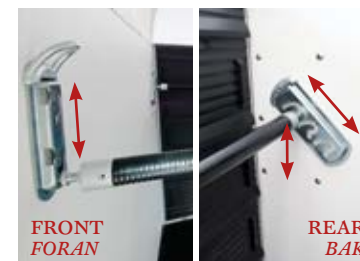

Space can be individually adjusted as the height of the front breast bars and height and length of the rear breast bars can be changed
 Individuell tilpasning ved hjelp av høydejusterbar foran og høyde- og lengdejusterbare bommer bak

5. Dividers / Skillevegger

Good for your horse. / Bra for hesten din.

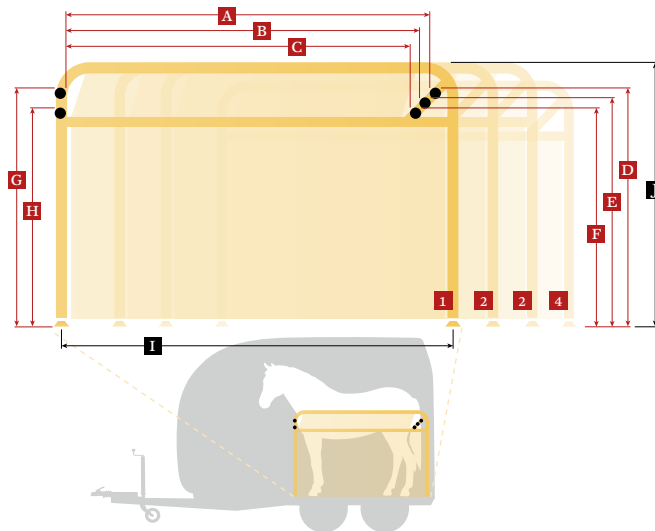

Our transparent PVC dividers, which can be moved to the right or left during loading, create an illusion of even greater space for the horse
 Optisk romforstørrelse ved gjennomsiktige PVC-skillevegg, som kan skyves bakover til høyre eller venstre ved lasting

	Wheelbase (mm)			Stall bar height at rear (mm)			Stall bar height at front (mm)		Divider wall dimensions (mm)	
	Stållengde (mm)			Bombhøyde bak (mm)			Bombhøyde foran (mm)		Skilleveggmål (mm)	
	A	B	C	D	E	F	G	H	I	J
1 T 180 For extra-large horses For svært store hester	1886	1836	1786	1313	1262	1212	1292	1192	2076	1310
2 T 165 For large horses For store hester	1816	1766	1716	1182	1131	1081	1181	1081	1945	1310
3 T 155 For medium-sized horses For middels store hester	1687	1637	1587	1182	1131	1081	1078	978	1816	1310
4 T 145 For small horses For små hester	1687	1637	1587	1032	981	931	928	828	1816	1160

Divider concept: The product designs already include the right dividers for your horse. On request you can equip your horse trailer with a divider that perfectly fits your horse.
 Skilleveggkonsept: I produktutførelsene er den riktige skilleveggen for din best allerede montert. Hvis det ønskes kan hestebengeren din utstyres med den skilleveggen som passer best for din best.

6. The Safety Concept / Sikkerhets-konseptet

Good for your horse. / Bra for hesten din.



No sharp edges - all hinges and bolt heads have been rounded off
 Ingen skarpe kanter grunnet de avrundete hengslene og skruehodene



No danger of the horse's hoofs slipping thanks to the closed rear struts with special perforation
 De lukkede og spesialbygde bakbommene gjør at hestebovene ikke sklir

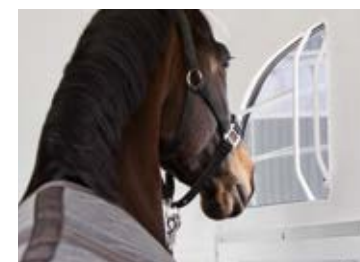

Head protection thanks to inset gratings in windows - no protruding edges and corners
 Det integrerte gitteret i vinduet gir hodebeskyttelse uten at hjørner og kanter står ut

*** Patented design and patent pending / Registrert varemerke og patentannmeldt

🇳🇴 Good for you.

We don't just make life easier for your horse but also for the rider. Many practical Böckmann innovations like the chassis, the door concept or the tack room have been proving their worth every day. Developed by practitioners for practitioners: simply good for you!

🇳🇴 Bra for deg.

Vi gjør livere lettere, ikke bare for bestene. Men også for alle ryttere. Man kan daglig nyte de mange praktiske Böckmann-oppfinnelsene som chassis, dør-konsept eller salkamre. Utviklet for å dekke dine behov: Rett og slett bra for deg!

1. Hitching and Unhitching / Til og frakobling



Easy to move around due to a tall and hard wearing automatic jockey wheel and perfectly positioned shunting handles
Behagelig parkering ved et høyt, belastbart automatstøttehjul og optimalt plassert parkeringshåndtak



Easy access to your boot thanks to the flat, heart-shaped handle and flat brake handle – even when hitched to the car
Det flate hjertegrepet til koblingen og den flate bremsespaken gir ubindret tilgang til bagasjerommet, også i tilkoblet tilstand



Good for you. / Bra for deg.

Drive-off and theft protection provided by a lockable cast-iron coupling with soft-top drive-off protection and rubberised, ergonomic, heart-shaped handle
Tyverisikring ved den låsbare koblingen med Soft-Top og gummielag, ergonomisk hjertegrep

2. Handling / Håndtering



Plenty of space for loading and unloading due to the large clearance between breast bar and tack room in the front area of the trailer
Mye plass ved lasting og lossing grunnet den store avstanden mellom bommen og salkammeret foran i tilhengeren



Easy to reach light switch thanks to a separate light switch for the interior lighting on the right access door
Man kommer lett til lysbryterne da det er separat lysbryter for den innvendige belysningen på den høyre siden av inngangsdøren



Good for you. / Bra for deg.

Quick access to the horse compartment thanks to a large access door and plenty of space once inside
Den store inngangsdøren gir rask tilgang til besterommet og mye plass innvendig

3. Driving Comfort / Kjørekomfort



Optimum road holding due to the lowered comfort suspension chassis* with wheel shock absorbers and soft suspension
Det lavtliggende komfortfjærings-chassiset med hjulstøtdempere gir optimalt veigrep og myk fjæring*



Even more comfort on the road with the world-class chassis* with galvanised independent wheel suspension, coil spring suspension and wheel shock absorbers
Enda mer kjørekomfort grunnet World-Class-chassiset med ildforsinket enkelthjuloppbening, skruefjæring og hjulstøtdempere*



Good for you. / Bra for deg.

More driving safety thanks to generously-dimensioned quality tyres
De store kvalitetsdekkene gir bedre kjøresikkerhet

4. Tying up Options / Tilkoblingsmulighetene

Good for you. / Bra for deg.

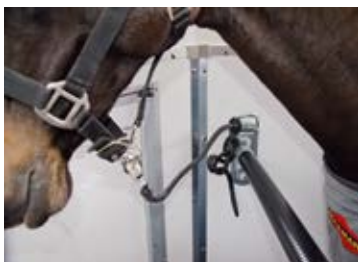

In the interior with metal eyes next to the front stall bars
Innvendig ved hjelp av metallmaljene ved siden av bommene foran



On the tail gate with 4 solid support bars - e.g. at events where trailers are parked close together
På baklemmen ved fire massive støttebøyer, f. eks. ved turneringer hvor tilhengerne står tett ved siden av hverandre



On the side wall by means of 4 Multi Safe System (MSS) fittings
På sideveggen ved hjelp av fire anordninger for Multi Safe System (MSS)

5. Doors / Dør-konseptet

Good for you. / Bra for deg.

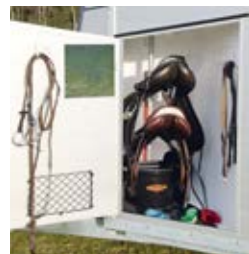

One key for all locks thanks to a master key in triplicate for the tack room door, access door and cast coupling
Tre universalnøkler til alle låsene til salkammeret, inngangsdøren og koblingen



Perfect closure due to 3-point door lock and rubber seal
Optimal låsemulighet med 3-punkts dørlås og gummitetting

6. Tack Rooms / Salkamrene

Good for you. / Bra for deg.



Standard tack room Duo, Champion, Comfort, Master (models also available as Western versions)
Standard-salkamrene Duo, Champion, Comfort, Master (modellene kan også fås som Western-versjon)



Large tack room Big Master (model also available as Western version)
Store salkamre Big Master (modellen kan også fås som Western-versjon)

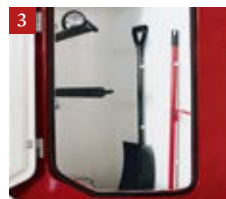

Standard tack room features** (Duo, Champion, Comfort, Master)
*Utstyr standard-salkammer** (Duo, Champion, Comfort, Master)*

- 1 Storage compartment in the bow (except Duo C and Champion C)
Hylle foran (ikke i Duo C og Champion C)
- 2 Tack room door with mirror, door net, bridle hook / *Salkammerdør med speil, dørrnett, trinsekrok*
- 3 Plastic shovel and telescopic brush / *Plastspade og teleskopkost*
- 4 Interior lighting with light switch / *Innelys med lysbryter*
- 5 Extendable, upholstered saddle rack / *Uttrekkelig, polstret sadelholder*
- 6 Saddlecloth holder (standard with some models) / *Sjabrakkstativ (delvis seriemessig)*
- 7 Tack room drainage for cleaning / *Salkammer-avløp ved rengjøring*
- 8 Sealed rubber flooring throughout / *Gjennomgående, forseglet gummigulv*
- 9 Appropriate ventilation / *Tvangslufting*
- 10 Guttering / *Regnlist*
 - Two additional, stable bridle hooks on the inside / *Ytterligere to stabile trinsekroker innvendig*































































Additional features for large tack rooms** (Big Master)
*Ytterligere utstyr stort salkammer** (Big Master)*

- 11 Second storage compartment in bow / *To hyller foran*
- 12 Second access door to tack room from interior / *To dører til salkammeret fra innsiden av hengeren*
 - Two mountable feeding troughs / *To førbokser som kan henges inn*

** For information on the tack rooms for the Uno, Portax and Traveller families, please refer to the corresponding product pages
Informasjoner ang. salkamre i Uno-, Portax- og Traveller-familien finner du på de respektive produktsidene























































🇬🇧 Your product finder.

🇳🇴 Produktsøker.

Design family <i>Designfamilie</i>	Basic model <i>Basismodell</i>	Page <i>Side</i>	Cover material <i>Oppbyggingsmaterial</i>	Ground plan <i>Grunnriss</i>	Interior dimensions* <i>Indre mål*</i>	Tack room <i>Salkammer</i>	Number of horses <i>Antall bester</i>	☛ Model type ☛ Modell-utførelse
 UNO & DUO	 UNO C	29	Ply wood/polyester cover <i>Plywood/polyesterbette</i>		3100 x 1300 x 2300	Classic (accessories) <i>Engelsk (tilbehør)</i>	 (or mare/foal) (<i>eller hoppe/fole</i>)	
	 NEW / NY UNO ESPRIT SILVER+BLACK	15	Plywood/polyester cover <i>Plywood/polyesterbette</i>		3100 x 1300 x 2300	Classic (accessories) <i>Engelsk (tilbehør)</i>	 (or mare/foal) (<i>eller hoppe/fole</i>)	
	 DUO ESPRIT C	24	Plywood/polyester cover <i>Plywood/polyesterbette</i>		3100 x 1650 x 2300	Classic (accessories) <i>Engelsk (tilbehør)</i>		
	 NEW / NY DUO ESPRIT SILVER+BLACK	17	Plywood/polyester cover <i>Plywood/polyesterbette</i>		3100 x 1650 x 2300	Classic (accessories) <i>Engelsk (tilbehør)</i>		
	 DUO C	24	Plywood/polyester cover <i>Plywood/polyesterbette</i>		3100 x 1650 x 2300	Classic (accessories) <i>Engelsk (tilbehør)</i>		☛ Carriage / Vogn p. /s. 64 ☛ Western p. /s. 64 ☛ Pony / Pommi p. /s. 65 ☛ Iceland Ponies / Islandsbest p. /s. 65
	 DUO R	25	Plywood/polyester cover <i>Plywood/polyesterbette</i>		3280 x 1650 x 2300	Engelsk		
 CHAMPION & COMFORT	 CHAMPION UNO C	29	Aluminium/polyester cover <i>eloks. Aluminium/polyesterbette</i>		3100 x 1300 x 2300	Classic (accessories) <i>Engelsk (tilbehør)</i>	 (or mare/foal) (<i>eller hoppe/fole</i>)	
	 NEW / NY CHAMPION UNO ESPRIT SILVER+BLACK	16	Aluminium/polyester cover <i>eloks. Aluminium/polyesterbette</i>		3100 x 1300 x 2300	Classic (accessories) <i>Engelsk (tilbehør)</i>	 (or mare/foal) (<i>eller hoppe/fole</i>)	
	 CHAMPION ESPRIT C	29	Aluminium/polyester cover <i>eloks. Aluminium/polyesterbette</i>		3100 x 1650 x 2300	Classic (accessories) <i>Engelsk (tilbehør)</i>		
	 NEW / NY CHAMPION ESPRIT SILVER+BLACK	18	Aluminium/polyester cover <i>eloks. Aluminium/polyesterbette</i>		3100 x 1650 x 2300	Classic (accessories) <i>Engelsk (tilbehør)</i>		☛ Carriage / Vogn p. /s. 64 ☛ Western p. /s. 64 ☛ Pony / Pommi p. /s. 65 ☛ Iceland Ponies / Islandsbest p. /s. 65
	 CHAMPION C	29	Aluminium/polyester cover <i>eloks. Aluminium/polyesterbette</i>		3100 x 1650 x 2300	Classic (accessories) <i>Engelsk (tilbehør)</i>		☛ Carriage / Vogn p. /s. 64 ☛ Western p. /s. 64 ☛ Pony / Pommi p. /s. 65 ☛ Iceland Ponies / Islandsbest p. /s. 65
	 CHAMPION R	30	Aluminium/polyester cover <i>eloks. Aluminium/polyesterbette</i>		3280 x 1650 x 2300	Classic <i>Engelsk</i>		
	 BIG CHAMPION R	30	Aluminium/polyester cover <i>eloks. Aluminium/polyesterbette</i>		3415 x 1750 x 2300	Classic <i>Engelsk</i>		☛ Western p. /s. 64
	 COMFORT	31	Full polyester <i>Hel polyester</i>		3240 x 1650 x 2300	Classic <i>Engelsk</i>		☛ Western p. /s. 64
 MASTER	 NEW / NY COMFORT ESPRIT SILVER+BLACK	19	Full polyester <i>Hel polyester</i>		3240 x 1650 x 2300	Classic <i>Engelsk</i>		
	 MASTER	35	Full polyester <i>Hel polyester</i>		3260 x 1650 x 2350	Classic <i>Engelsk</i>		
	 BIG MASTER	36	Full polyester <i>Hel polyester</i>		3600 x 1750 x 2300	Classic <i>Engelsk</i>		☛ Western p. /s. 64
	 NEW / NY BIG MASTER L	36	Full polyester <i>Hel polyester</i>		3900 x 1750 x 2300	Classic <i>Engelsk</i>		☛ Western p. /s. 64
	 NEW / NY GRAND MASTER SKA	37	Full polyester <i>Hel polyester</i>		3900 x 1750 x 2300	Classic <i>Engelsk</i>		☛ Western p. /s. 64
	 NEW / NY GRAND MASTER SR	37	Full polyester <i>Hel polyester</i>		3900 x 1750 x 2300	Classic <i>Engelsk</i>		

C = Compact (flat bow) | R = Round, aerodynamic bow (standard equipment with tack room)
C = Compact (stump foran) | R = Rund, aerodynamisk foran (seriemessig med salkammer)

* (length x width x height in mm)
(lengte x bredde x høigte in mm)

Design family <i>Designfamilie</i>	Basic model <i>Basismodell</i>	Page <i>Side</i>	Cover material <i>Oppbyggingsmaterial</i>	Ground plan <i>Grunnriss</i>	Interior dimensions* <i>Indre mål*</i>	Tack room <i>Salkammer</i>	Number of horses <i>Antall hester</i>	⊕ Model type <i>⊕ Modell-utførelse</i>	
 PORTAX	 PORTAX SKA	41 - 43	Aluminium/polyester cover <i>eloks. Aluminium/polyesterbette</i>		3495 x 1750 x 2300	Classic/Western (operated from outside) <i>Engelsk/Western (kan betjenes utenfra)</i>			
	 PORTAX E	41 - 43	Aluminium/polyester cover <i>eloks. Aluminium/polyesterbette</i>		3495 x 1750 x 2300	Classic (in bow) <i>Engelsk (foran)</i>			
	 PORTAX K	41 - 43	Aluminium/polyester cover <i>eloks. Aluminium/polyesterbette</i>		3495 x 1750 x 2300	Classic/Western (in bow) <i>Engelsk/Western (foran)</i>			
	 PORTAX L SR	46 - 49	Aluminium/polyester cover <i>eloks. Aluminium/polyesterbette</i>		4125 x 1750 x 2300	Classic/Western (walk-in) <i>Engelsk/Western (kan gås inn i)</i>			
	 PORTAX L SKA	46 - 49	Aluminium/polyester cover <i>eloks. Aluminium/polyesterbette</i>		4125 x 1750 x 2300	Classic/Western (operated from outside) <i>Engelsk/Western (kan betjenes utenfra)</i>			
	 PORTAX L E	46 - 49	Aluminium/polyester cover <i>eloks. Aluminium/polyesterbette</i>		4125 x 1750 x 2300	Classic/Western (operated from outside) <i>Engelsk/Western (kan betjenes utenfra)</i>			
	 PORTAX L K	46 - 49	Aluminium/polyester cover <i>eloks. Aluminium/polyesterbette</i>		4125 x 1750 x 2300	Classic/Western (operated from inside) <i>Engelsk/Western (kan betjenes innenfra)</i>			
	 BIG PORTAX	52	Aluminium/polyester cover <i>eloks. Aluminium/polyesterbette</i>		4150 x 1850 x 2400	Classic (walk-in) <i>Engelsk (kan gås inn i)</i>			
	 MEGA PORTAX	53	Aluminium/polyester cover <i>eloks. Aluminium/polyesterbette</i>		4200 x 2000 x 2550	Classic (walk-in) <i>Engelsk (kan gås inn i)</i>		(max. permissible total weight of the horses: 1300 kg) <i>(maks. tillatt totalvekt av hester: 1300 kg)</i>	
 TRAVELLER	For small horses of height up to approx. 145 cm / For små hester med mankehøyde på inntil ca. 145 cm								
		TRAVELLER K3				3170 x 2000 x 2100			(2 - 3)
		TRAVELLER K3 BIG SK*				3570 x 2000 x 2100			(2 - 3)
		TRAVELLER K4	57	Aluminium/polyester cover <i>eloks. Aluminium/polyesterbette</i>		3570 x 2000 x 2100	walk-in, 3 saddle racks <i>man kan gå inn, 3 sadelboldere</i>		(3 - 4)
		TRAVELLER K4 BIG SK*				4570 x 2000 x 2100			(3 - 4)
		TRAVELLER K5				4570 x 2000 x 2100			(4 - 5)
For medium-sized horses of height up to approx. 155 cm / For middels store hester med mankehøyde på inntil ca. 155 cm									
	TRAVELLER W2 BIG SK*				3570 x 2000 x 2400	walk-in, 2 saddle racks for large saddles <i>man kan gå inn, 2 sadelboldere for store sadler</i>			
	TRAVELLER W3	58	Aluminium/polyester cover <i>eloks. Aluminium/polyesterbette</i>		3570 x 2000 x 2400	walk-in, 3 saddle racks for large saddles <i>man kan gå inn, 3 sadelboldere for store sadler</i>		(2 - 3)	
	TRAVELLER W3 BIG SK*				4570 x 2000 x 2400			(2 - 3)	
	TRAVELLER W4				4570 x 2000 x 2400	walk-in, 4 saddle racks for large saddles <i>man kan gå inn, 4 sadelboldere for store sadler</i>		(3 - 4)	
For large horses of height up to approx. 165 cm / For store hester med mankehøyde inntil ca. 165 cm									
	Traveller G2	59	Aluminium/polyester cover <i>eloks. Aluminium/polyesterbette</i>		3570 x 2000 x 2400	walk-in, 2 saddle racks <i>man kan gå inn, 2 sadelholderer</i>			
	Traveller G3				4570 x 2000 x 2400	walk-in, 3 saddle racks <i>man kan gå inn, 3 sadelholderer</i>			

** Extra-large tack room with large door and large, swivel saddle racks
Ekstra stort salkammer med større dører og store svingbare sadelboldere

Changes to design and equipment reserved. Weights and dimensions approximate; can change due to additional equipment. Some illustrations and floor plans do not depict standard equipment.
Vi forbeholder oss retten til å foreta konstruksjons- og utstyrsendringer. Vekt og mål er tilnærmet. De kan endre seg grunnet tilleggsutstyret. Illustrasjonene og grunnrissene tilsvarer delvis ikke seriestyret.

🇬🇧 The Esprit silver+black models.

🇳🇴 *Esprit-modellene silver+black.*



MAXIMUM FUNCTIONALITY
AND A WHOLE LOT OF ESPRIT:
THE PERFECT COMPANION
FOR THE EVERYDAY LIFE
OF A RIDER.

Thanks to their classic design and the classy colour scheme, our new Esprit silver+black models are real eye-catchers. A well thought-out standard features make them practical and at the same time extremely trendy companions – and that at an attractive price.

**TOPP FUNKSJONALITET
OG MYE ENERGI: EN PERFEKT
OG TROFAST LEDSAGER FOR
HEST OG RYTTER.**

*De nye modellene Esprit silver+black
tiltrekker seg mye oppmerksomhet, med den
klassiske designen og elegante fargesettingen.
Gjennomtenkt standardutstyr gjør modellene
til praktiske og stilige ledsagere på veien –
dessuten med attraktivt pris.*



NEW / NY

**UNO ESPRIT
SILVER+BLACK**
Page 15 / Side 15



NEW / NY

**CHAMPION
UNO ESPRIT
SILVER+BLACK**
Page 16 / Side 16



NEW / NY

**DUO ESPRIT
SILVER+BLACK**
Page 17 / Side 17



NEW / NY

**CHAMPION
ESPRIT
SILVER+BLACK**
Page 18 / Side 18



NEW / NY

**COMFORT
ESPRIT
SILVER+BLACK**
Page 19 / Side 19



UNO ESPRIT
SILVER+BLACK

UNO ESPRIT SILVER+BLACK

 Durable and safe: The well thought-out equipment details of the new Uno Esprit silver+black, such as the tarpaulin lift for an optimum interior atmosphere or steel rims and impact-resistant synthetic mudguards, guarantee you not only the well-being of your horse, but also safe road holding.





 Holdbar og sikker: De gjennomtenkte utstyrsdetaljene på nye Uno Esprit silver+black, for eksempel rullegardin for optimalt inneklima, eller stålfelger og slagfaste plastskjermmer, garanterer både hestens velvære og sikre kjøreegenskaper.

Highlight / Highlight



Everything in its place, thanks to the optional, internal tack room and the saddle rack mounted on the inside of the door
Alt finner sin plass ved hjelp av det opsjonale, interne salkammeret og sadelholderne som er montert på innsiden av døren

At a glance / Kort oversikt

Number of horses / Antall hester	 (or mare/foal) / (eller hoppe/fole)
Structure (Plywood)* Oppbygging (Plywood)*	Standard: Serie:  
Cover (Polyester)* Hette (Polyester)*	Standard: Serie:  
Chassis (standard) / Chassis (serie)	Lowered rubber spring axle with excellent road holding Senket gummifjæraksel med svært gode kjøreegenskaper

Highlight of the standard equipment Highlight blant serieutstyret



Tail gate with rubber mat
Baklem med gummimatte



Esprit tarpaulin lift
Esprit rullegardin



Impact-resistant mudguards
Slagfaste plastskjermmer





Complete standard equipment Komplett serieutstyret	Page 20 - 21 Side 20 - 21
Accessories Tilbehørsprogram	Page 66 - 68 Side 66 - 68







CHAMPION UNO
ESPRIT
SILVER+BLACK

CHAMPION UNO ESPRIT SILVER+BLACK

 With the Champion Uno Esprit silver+black you transport your horse safely and conveniently. The robust aluminium superstructure and the impact-resistant synthetic mudguards are perfectly complemented with trendy, optical highlights, such as anthracite-coloured wheel trims.

 Med Champion Uno Esprit silver+black transporteres besten sikkert og komfortabelt. Det kraftige aluminiumpåbygget og de slagfaste plasticskjermene kompletteres perfekt av elegante visuelle detaljer som antrasittfargete hjulkapsler.

At a glance / Kort oversikt

Number of horses / Antall hester	 (or mare/foal) / (eller hoppe/fole)
Structure (Anodised aluminium)* Oppbygging (Eloksert aluminium)*	
Cover (Polyester)* Hette (Polyester)*	Standard:  Serie: 
Chassis (standard) / Chassis (serie)	Lowered rubber spring axle with excellent road holding Senket gummi fjæraksel med svært gode kjøreegenskaper

Highlight of the standard equipment Highlight blant seriestyret



Tail gate with rubber mat
Baklem med gummi matte



Esprit tarpaulin lift
Esprit rullegardin



Impact-resistant mudguards
Slagfaste plasticskjermer

Highlight / Highlight

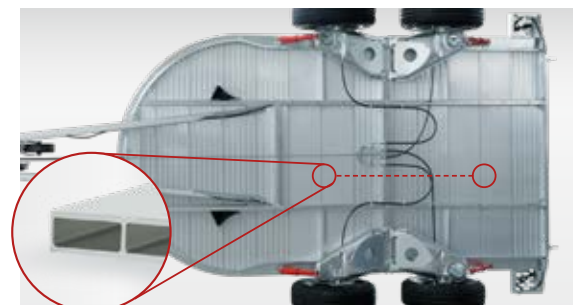

Robust and rot-proof thanks to the solid quality full aluminium floor
Robust og råtefri grunnet det massive kvalitets-aluminiumsgulv





Complete standard equipment Komplett seriestyret	Page 20 - 21 Side 20 - 21
Accessories Tilbørsprogram	Page 66 - 68 Side 66 - 68



DUO ESPRIT
SILVER+BLACK

DUO ESPRIT SILVER+BLACK

 Regardless of whether you're a passionate competition or an ardent recreational rider: The safety stall bar system height-adjustable at the front and the lowered rubber spring axle of the new Duo Esprit silver+black guarantee maximum safety and high driving comfort – for both horse and rider.





 Uansett om du er pasjonert turneringsrytter eller lidenskapelig fritidsrytter: Stangsystemet foran i sikkerhetsboksen som kan reguleres i høyden, og den senkede gummi fjærakselen på nye Duo Esprit silver+black, garanterer maksimal sikkerhet og høy kjørekomfort – både for deg og hesten.

Highlight / Highlight

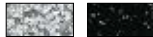

Everything in its place, thanks to the optional, internal tack room and the saddle rack mounted on the inside of the door
Alt finner sin plass ved hjelp av det opsjonale, interne salkammeret og sadelholderne som er montert på innsiden av døren

At a glance / Kort oversikt

Number of horses / <i>Antall hester</i>	
Structure (Plywood)* <i>Oppbygging (Plywood)*</i>	Standard:  Serie: 
Cover (Polyester)* <i>Hette (Polyester)*</i>	Standard:  Serie: 
Chassis (standard) / <i>Chassis (serie)</i>	Lowered rubber spring axle with excellent road holding <i>Senket gummi fjæraksel med svært gode kjøreegenskaper</i>

Highlight of the standard equipment *Highlight blant serieutstyret*



Tail gate with rubber mat
Baklem med gummi matte



PVC partition
Skillevegg i PVC



Impact-resistant mudguards
Slagfaste plastskjærmer





Complete standard equipment <i>Komplett serieutstyret</i>	Page 20 – 21 <i>Side 20 – 21</i>
Accessories <i>Tilbehørsprogram</i>	Page 66 – 68 <i>Side 66 – 68</i>



CHAMPION ESPRIT
SILVER+BLACK

CHAMPION ESPRIT SILVER+BLACK

 It is a perfect companion for the everyday life of a rider: With its robust aluminium superstructure and the safe PVC partition wall, the Champion Esprit silver+black is not only a small spatial miracle, it also scores points for both driving comfort and maximum safety.



 It is a perfect companion for the everyday life of a rider: With its robust aluminium superstructure and the safe PVC partition wall, the Champion Esprit silver+black is not only a small spatial miracle, it also scores points for both driving comfort and maximum safety.

At a glance / Kort oversikt

Number of horses / Antall hester



Structure (Anodised aluminium)*
Oppbygging (Eloksert aluminium)*

Standard: 
Serie: 

Cover (Polyester)*
Hette (Polyester)*

Standard: 
Serie: 

Chassis (standard) / Chassis (serie)

Lowered rubber spring axle
with excellent road holding
Senket gummi fjæraksel
med svært gode kjøreegenskaper

Highlight of the standard equipment Highlight blant seriestyret



Tail gate with rubber mat
Baklem med gummi matte



PVC partition
Skillevegg i PVC



Impact-resistant mudguards
Slagfaste plastskjermmer

Highlight / Highlight

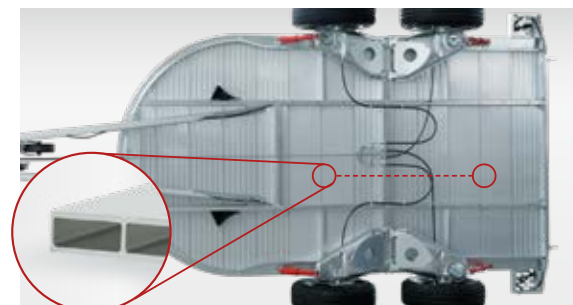

Robust and rot-proof thanks to the solid quality
full aluminium floor

Robust og råtefri grunnet det massive kvalitets-aluminiumsgulv



Complete standard equipment
Komplett seriestyret

Page 20 - 21
Side 20 - 21

Accessories
Tilbørsprogram

Page 66 - 68
Side 66 - 68

COMFORT ESPRIT
SILVER+BLACK

COMFORT ESPRIT SILVER+BLACK

 The all-polyester superstructure and the solid quality all-aluminium floor of the new Comfort Esprit silver+black make it especially robust and durable. At the same time, it impresses with easy towing and safe road holding.

 Nye Comfort Esprit silver+black er utstyrt med et helpolyester-påbygg og kraftig belaluminiumsgulv i toppkvalitet, som gjør hengeren svært robust og holdbar. Samtidig overbeviser den fordi den er lett å trekke og har sikre kjøreegenskaper.

Highlight / Highlight



Plenty of space with the polyester saddle box with a feed trough, synthetic shovel, mirror on the door and the pull-out saddle rack, which is vertically and horizontally adjustable

Mye plass takket være salkisten i polyester, med førboks, plastspade, dørrnett, speil på døra og sadelholderen som kan trekkes ut og justeres både i høyden og mot siden.

At a glance / Kort oversikt

Number of horses / Antall hester



Structure (Full Polyester)*
Oppbygging (Helpolyester)*

Standard:
Serie:



Chassis (standard) / Chassis (serie)

Lowered rubber spring axle
with excellent road holding

*Senket gummi fjæraksel
med svært gode kjøreegenskaper*

Highlight of the standard equipment Highlight blant seriestyret



Tail gate with rubber mat
Baklem med gummatte



PVC partition
Skillevegg i PVC



Impact-resistant mudguards
Slagfaste plastskjerner

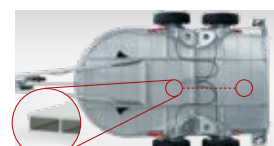

Solid quality all-aluminium floor
Kraftig belaluminiumsgulv i toppkvalitet



Complete standard equipment
Komplett seriestyret



















Page 20 - 21
Side 20 - 21

Accessories
Tilbehørsprogram

Page 66 - 68
Side 66 - 68

Standard equipment.

Serieutstyret.

									
 UNO ESPRIT SILVER + BLACK	1600 kg	2730 mm	1860 mm	4500 mm	2300 mm	1300 mm	3100 mm	900 kg	
 CHAMPION UNO ESPRIT SILVER + BLACK	1600 kg	2730 mm	1830 mm	4490 mm	2300 mm	1300 mm	3100 mm	896 kg	
 DUO ESPRIT SILVER + BLACK	2000 kg	2730 mm	2200 mm	4500 mm	2300 mm	1650 mm	3100 mm	1191 kg	
 CHAMPION ESPRIT SILVER + BLACK	2000 kg	2730 mm	2200 mm	4500 mm	2300 mm	1650 mm	3100 mm	1165 kg	
 COMFORT ESPRIT SILVER + BLACK	2000 kg	2730 mm	2200 mm	4500 mm	2300 mm	1650 mm	3280 mm	1151 kg	

All rights to changes in design and equipment reserved. Weights and dimensions approximate; changes due to additional equipment possible.
Vi forbeholder oss retten til å foreta konstruksjons- og utstyrsendringer. Vekt og mål er tilnærmet. De kan endre seg grunnet tilleggsutstyret.

* Curb weight reduction possible
Reduksjon i samlet vekt mulig

UNO ESPRIT

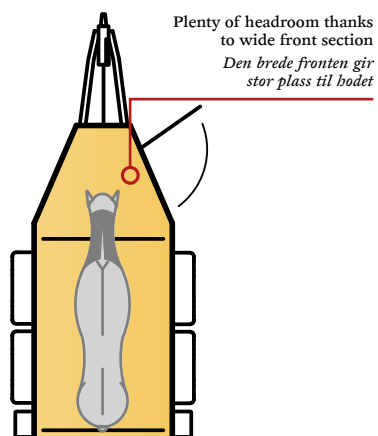

CHAMPION UNO ESPRIT

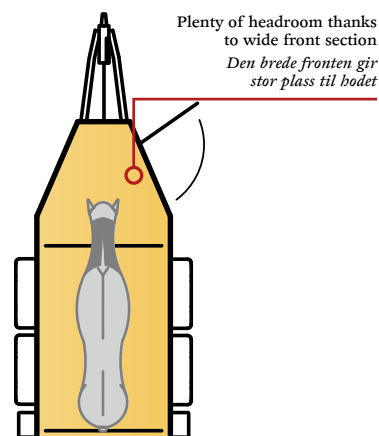

DUO ESPRIT

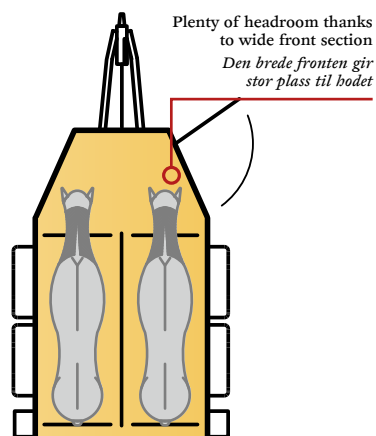

CHAMPION ESPRIT

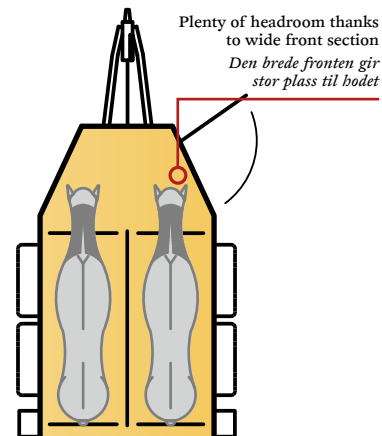

COMFORT ESPRIT

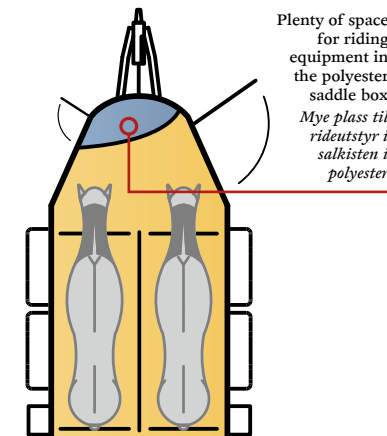

Chassis / Chassis



Good road holding thanks to the 13" quality tyres
Gode kjøreegenskaper takket være 13" kvalitetsdekk

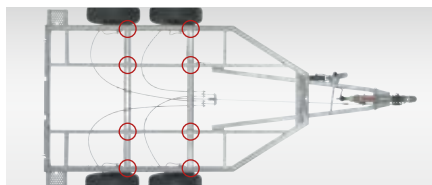

Made for heavy loads with axles bolted 8x to the longitudinal beam construction and a welded, hot-galvanised steel frame
Laget for høy belastning ved aksene som er skrudd fast til lengdedragerkonstruksjonen på 8 steder og sveisete, ildforsinkete stålrammer



Safe hitching and unhitching thanks to the coupling and the ergonomic brake lever
Sikker til- og frakopling ved hjelp av koplingen og det ergonomiske bremsehåndtaket

Additional standard features:

- Bolted v-shaped towing bar with automatic jockey wheel
- Large illumination unit with reversing light and 13-pin plug

Ytterligere serieutstyret:

- Fastskrudd v-vognstang med autom. støttehjul
- Stor belysningsenhet med ryggelys og 13-polet plugg

Structure / Ytre oppbygging



Attractive design and fresh air due to (the) polyester roof with large, glare-free pop-out windows for optimum air intake (Comfort Esprit silver+black with different window design)

Den sølv-metallic polyesterbetten med store, blendefrie vippevinduer for optimalt luftinntak gjør den formskjønn og til et friskt pust (Comfort Esprit silver+black med avvikende vindusløsning)



Optimum interior atmosphere thanks to Esprit tarpaulin lift
Optimalt romklima ved hjelp av Esprit rullgardinen



Secure footing with the step on the tail gate
Sikkert trinn på baklemmen

Additional standard features:

- Stainless steel 304 bolts on structure
- Impact-resistant composite mudguards
- Lifting device on rear gate
- 4 steel struts at the rear hatch and 2 solid rear struts with special perforation per side
- Lockable doors with 3-point door locking system

Ytterligere serieutstyret:

- V2A-edelståltilskruing ved oppbyggingen
- Slagfast plast-skvettlapp
- Løfteutstyr på baklemmen
- 4 stålstag på bakluken og 2 massive, spesialbullede bakbjelker pr. side
- Låsbare dører med 3-punkts-dørlås

Interior / Utstyr innvendig



Tail gate with rubber mat
Baklem med gummatte



Comfortable standing position thanks to safety stall bar system
Komfortabel transport takket være stangsystemet i sikkerhetsboksen



Polyester saddle box with a feed trough, synthetic shovel, door net, mirror on the door and the pull-out saddle rack, which is vertically and horizontally adjustable (only Comfort Esprit silver + black)
Sadelkisten i polyester, med førboks, plastspade, dørnnett, speil på døra og sadelholderen som kan trekkes ut og justeres både i høyden og mot siden (kun Comfort Esprit silver+black)

Additional standard features:

- Transparent PVC divider
- Rubber matting with anti-slip structure, glued and sealed
- Interior lighting

Ytterligere serieutstyret:

- Gjennomsiktig PVC-skillevegg
- Gummigulv med sklisikkert tekestilstruktur, fastlimt og forseglet
- Innebelysning med separat bryter

🇬🇧 The Uno & Duo family.
🇳🇴 Uno & Duo-familien.



**OBVIOUS BENEFITS:
DISTINCTIVE DESIGN –
MAXIMUM FUNCTIONALITY.**

With its striking design the new Uno & Duo family is genuinely eye-catching. Due to the aerodynamic lines, these modules are very easy to tow, and thus substantially reduce fuel consumption. Not directly recognisable at first glance, but just as innovative – the many other features developed to suit practical needs. Starting with the base model Duo Esprit C, the Uno and Duo product family offers comprehensive features at an attractive price.

**STORE FORDELER:
MARKANT DESIGN –
HØYESTE FUNKSJONALITET.**

Den markante designen gjør Uno & Duo-familien til noe helt spesielt. Med sin aerodynamiske form er modellen spesielt lett og det reduserer bensinforbruket merkbart. Man ser det ikke med en gang, men like innovative er de mange utstyrsdetaljene, som er utviklet til bruk i praksis. Fra startmodellen Duo Esprit C gir Uno og Duo familiene deg omfattende utstyr til attraktiv pris.



UNO C
Page 23
Side 23

DUO C
DUO ESPRIT C
Page 24
Side 24

DUO R
Page 25
Side 25



















UNO C

UNO C

 Benefit from many Böckmann detail solutions included as standard with our Uno models: for example, the polyester cover in silver-metallic, the original Böckmann tail gate flooring, 3-point door locking – and much more!

 *Uno-modellene nyter godt av de mange detaljløsningene fra Böckmann i serieutstyret: For eksempel polyesterhette i sølv-metallic, det originale Böckmann-baklebelegget, tre-punkts-dørlåsen og mye mer!*

At a glance / Kort oversikt

Number of horses / Antall bester	 (or mare/foal) / (eller hoppe/fole)
Structure (Plywood)* Oppbygging (Plywood)*	Standard:   Serie: 
Cover (Polyester)* Hette (Polyester)*	Without surcharge: Uten tillegg i prisen:     With surcharge: Med tillegg i prisen:        
Chassis (standard) / Chassis (serie)	
Standard equipment / Serieutstyret	Safety stall bar system with chains Sikkerhetsbomsystem med små kjeder

Highlight / Highlight



Everything in its place, thanks to the optional, internal tack room and the saddle rack mounted on the inside of the door
Alt finner sin plass ved hjelp av det opsjonale, interne salkammeret og sadelholderne som er montert på innsiden av døren



CHAMPION UNO C





Complete standard equipment Komplett serieutstyret	Page 26 – 27 Side 26 – 27
Accessories Tilbehørsprogram	Page 66 – 68 Side 66 – 68



Duo C

DUO C DUO ESPRIT C









 Our base models Duo Esprit C and Duo C offer premium quality at a reasonable price. Both models are particularly well-built thanks to the sturdy plywood platform.

 Våre startmodeller Duo Esprit C og Duo C gir høyeste kvalitet for en god pris. Begge modellene har en svært robust konstruksjon, takket være et stabilt påbygg av kryssfiner.

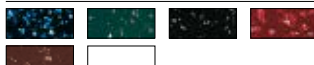

DUO ESPRIT C

At a glance / Kort oversikt

Number of horses / Antall bester	Duo C:  Duo Esprit C: 
Structure (Plywood)* Oppbygging (Plywood)*	Standard:  Serie: 
Cover (Polyester)* (except Duo Esprit C) Hette (Polyester)* (unntatt Duo Esprit C)	Without surcharge: Uten tillegg i prisen:  With surcharge: Med tillegg i prisen: 
Chassis (standard) / Chassis (serie)	
Chassis (option, except Duo Esprit C) Chassis (optie, unntatt Duo Esprit C)	
Standard equipment (except Duo Esprit C) Serieutstyret (unntatt Duo Esprit C)	Multi Safe System** 

Highlight of the standard equipment Hightlight blant serieutstyret



The height and longitudinally adjustable safety stall bar system (panic system) Multi Safe System** for front and rear (except Duo Esprit C)
Det høyde- og lengdejusterbare sikkerhetsbomsystemet (panikkssystem) Multi Safe System** for foran og bak (unntatt Duo Esprit C)

	Complete standard equipment Komplett serieutstyret	Page 26 - 27 Side 26 - 27
	Accessories Tilbehørsprogram	Page 66 - 68 Side 66 - 68









Duo R

Duo R

 The aerodynamic Duo R provides your horse with plenty of headroom, and apart from its luxurious appearance thanks to the generous Böckmann polyester bow, it gives you plenty of extra space in the standard tack room, including – among other features – extendable and height adjustable saddle racks.

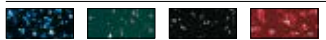
 Den aerodynamiske Duo R gir besten din mye plass til hodet og i tillegg til en høyverdig optikk får du mye tilleggs plass i det seriemessige salkammeret med den storslagne Böckmann polyesterfronten. Blant annet med uttrekkbare og høydejusterbare sadelholdere.

At a glance / Kort oversikt

Number of horses / Antall bester	
Structure (Plywood)* Oppbygging (Plywood)*	Standard: Serie: 
	Standard: Serie: 
Cover (Polyester)* Hette (Polyester)*	Without surcharge: Uten tillegg i prisen: 
	With surcharge: Med tillegg i prisen: 
Chassis (standard) / Chassis (serie)	
Chassis (option, except Duo Esprit C) Chassis (optie, unntatt Duo Esprit C)	
Standard equipment (except Duo Esprit C) Serieutstyret (unntatt Duo Esprit C)	Multi Safe System** 

Highlight of the standard equipment Highlight blant serieutstyret



Tack room with storage compartment, extendable saddle racks, shovel, brush, mirror, door net, saddle cloth holder and interior lighting
Salkammer med hylle, uttrekkbare sadelholdere, spade, børste, speil, dørrnett, sjabrakkstativ og innebelysning



Complete standard equipment Komplett serieutstyret	Page 26 – 27 Side 26 – 27
Accessories Tilbehørsprogram	Page 66 – 68 Side 66 – 68

🇬🇧 Standard equipment.

🇳🇴 Seriestyret.

UNO C	1600 kg*	2730 mm	1860 mm	4500 mm	2300 mm	1300 mm	3100 mm	848 kg	(or mare/foal) (eller hoppe/føle)
DUO ESPRIT C	2000 kg*	2730 mm	2200 mm	4500 mm	2300 mm	1650 mm	3100 mm	1161 kg	
DUO C	2400 kg*	2730 mm	2200 mm	4500 mm	2300 mm	1650 mm	3100 mm	1539 kg	
DUO R	2400 kg*	2730 mm	2200 mm	4500 mm	2300 mm	1650 mm	3280 mm	1509 kg	

All rights to changes in design and equipment reserved. Weights and dimensions approximate; changes due to additional equipment possible.
Vi forbeholder oss retten til å foreta konstruksjons- og utstyrsendringer. Vekt og mål er tilnærmet. De kan endre seg grunnet tilleggstyret.

* Curb weight reduction possible
Reduksjon i samlet vekt mulig

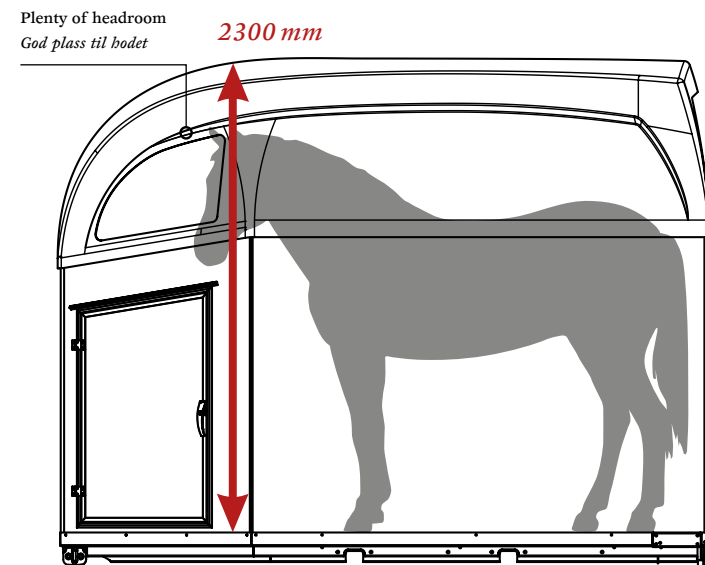
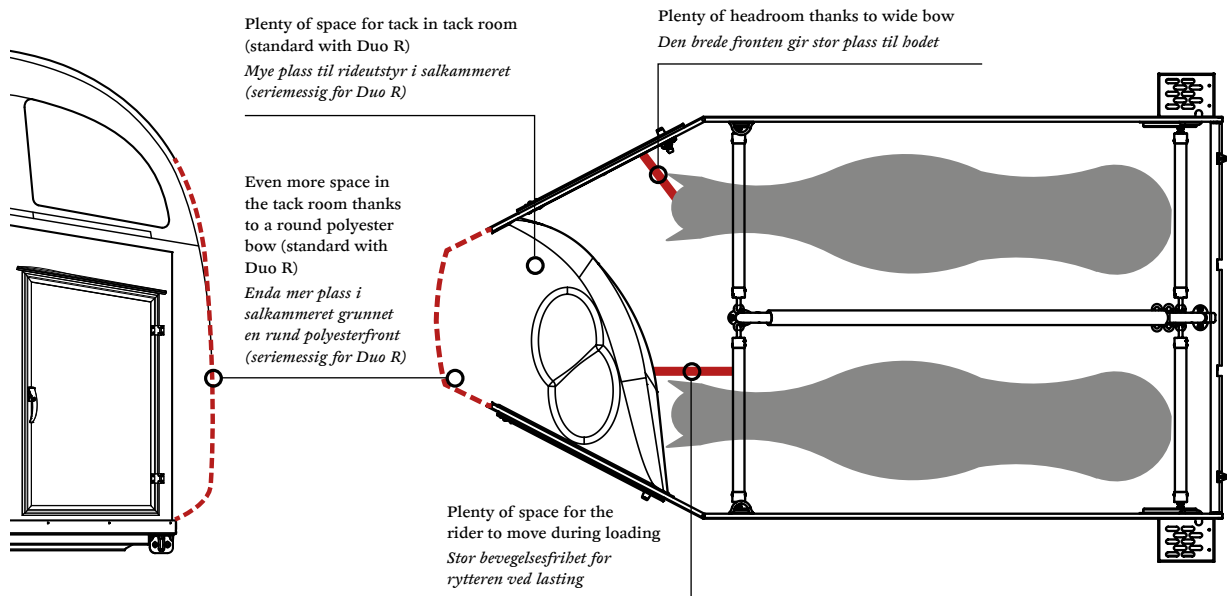

Chassis / Chassis



Perfect road holding thanks to lowered Comfort suspension chassis with wheel shock absorbers
Optimale kjøreegenskaper grunnet det senkede Comfort-fjæringssystemet med hjulstøtdempere

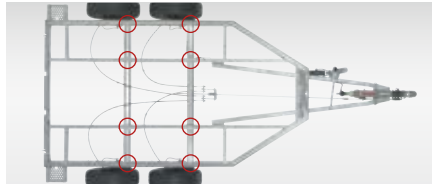

Made for heavy loads with axles bolted 8x to the longitudinal beam construction and a welded, hot-galvanized steel frame
Laget for høy belastning ved aksene som er skrudd fast til lengdedragerkonstruksjonen på 8 steder og sveisete, ildforsinkete stålrammer



Safe hitching and unhitching thanks to lockable cast coupling with padded comfort handle and soft top (drive-off protection, Duo Esprit C with non-lockable standard coupling)

Sikker til og frakobling ved hjelp av låsbare koblinger med tildekket komforthåndtak og Soft-Top (startspærre, Duo Esprit C med standardkobling, ikke låsbar)

Additional standard features:

- Bolted v-shaped towing bar with automatic jockey wheel
- Large illumination unit with reversing light and 13-pin plug
- Generously dimensioned 14" quality tyres (Duo Esprit C: 13")

Ytterligere serieutstyret:

- *Fastskrudd v-vognstang med autom. støttehjul*
- *Stor belysningsenhet med ryggelys og 13-polet plugg*
- *Stordimensjonert 14" kvalitetsdekk (Duo Esprit C: 13")*

Structure / Ytre oppbygging



Attractive and with fresh air thanks to silver-metallic polyester top with large, dazzle-free opening windows for optimum air intake (Duo Esprit C with different window design)

Den sølv-metallic polyesterbetten med store, blende frie vippevinduer for optimalt luftinntak gjør den forrskjønn og til et friskt pust (Duo Esprit C med avvikende vindusløsning)



Optimum interior atmosphere thanks to tarpaulin lift with integrated net**, also protects against rain and cold (Duo Esprit C, only tarpaulin lift)

*Optimalt romklima ved hjelp av rullgardinen med integrert nett**, beskytter mot regn og kulde (Duo Esprit C kun planlift)*



Solid workmanship with the high-quality number plate holder and two integrated steps (Duo Esprit C with single ramp)

Massivt trinn grunnet de bøyverdige Registreringskilt holder med to integrerte trinn (Duo Esprit C med enkel utgang)

Additional standard features:

- Composite clad plywood structure
- Stainless steel 304 bolts on structure
- Impact-resistant composite mudguards
- Lifting device on rear gate
- 4 steel struts at the rear hatch (Uno with 3 steel struts) and 2 solid rear struts with special perforation per side, rear strut closed (except Duo Esprit C)
- Manoeuvring handle (except Duo Esprit C)
- Decor stripes on side wall with horse head (except Duo Esprit C)
- Lockable doors with 3-point door locking system

Ytterligere serieutstyret:

- *Plastbelagt Plywood-opbygging*
- *V2A-edelståltilskruing ved oppbyggingen*
- *Slagfast plast-skvettlapp*
- *Løfteutstyr på baklemmen*
- *4 stålstag på bakluken (Uno med 3 stålstag og 2 massive, spesialhullede bakkjelker pr. side, bakre bjelke lukket (unntatt Duo Esprit C)*
- *Parkeringshåndtak (unntatt Duo Esprit C)*
- *Dekorasjonsstriper med bestebode på sideveggen (unntatt Duo Esprit C)*
- *Låsbare dører med 3-punkts-dørlås*

Interior / Utstyr innvendig



The height and longitudinally adjustable safety stall bar system (panic system) Multi Safe System*** for front and rear (Uno and Duo Esprit C with safety chain)

*Det høyde- og lengdejusterbare sikkerhetsbom-systemet (panikk-system) Multi Safe System*** for foran og bak (Uno og Duo Esprit C med små sikkerhetskjeder)*

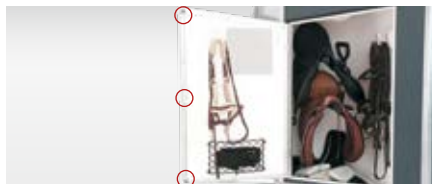

Practical tack room (standard with Duo R) with 3-point door locking; a single master key locks all doors and the cast coupling (except Duo Esprit C)

Praktisk salkammer (seriemessig for Duo R) med 3-punkts-dørlås; en universalnøkkel låser alle dørene og koblingen (unntatt Duo Esprit C)



Firm foothold due to special lateral treads and side stops on the rear ramp covering
Spesialtverrtrinnslister og sidestopp på baklembelegget gir optimalt feste

Additional standard features:

- Transparent PVC divider, flexible with PVC top section (except Uno C, Duo Esprit C)
- Rubber matting with anti-slip structure, glued and sealed
- Calming blue LED transport light with separate switch - can be switched over from white to blue
- Duo R: Tack room with storage compartment, extending saddle racks with adjustable height, plastic shovel, telescopic brush, mirror, door net, saddle cloth holder and interior lighting

Ytterligere serieutstyret:

- *Gjenomsiktig PVC-skillevegg, fleksibel med PVC-overdel (unntatt Uno C, Duo Esprit C)*
- *Gummigulv med sklisikkert tekstilstruktur, fastlimt og forseglet*
- *Beroligende, blått LED-transportlys med separat bryter - mulig å skifte fra hvitt til blått lys*
- *Duo R: Salkammer med hylle, uttrekkbare og høydejusterbare sadelholdere, plastsjåve, teleskopbørste, speil, dørrnett, sjabakkstativ og innebelysning*

 **The Champion & Comfort family.**
 *Champion & Comfort-familien.*



LOOK OUTSTANDING. MEET THE HIGHEST DEMANDS.

The Champion family with anodised aluminium superstructure and the Comfort family with reinforced solid polyester superstructure are very robust and durable. Equipped for daily use. The standard highlights such as the Multi Safe System (MSS) safety stall bar system, the solid quality full aluminium floor or the tack room in the polyester bow meet the highest demands of horse and rider. However, all this efficiency does not affect the style – the unique design is appealing from top to bottom and leaves a lasting impression wherever you go.

SER FLOTT UT. OVERHOLDER DE HØYESTE KRAVENE.

Champion-familien med elokserende aluminiumsoppbygging og Comfort-familien med forsterket helpolyesteroppbygging er spesielt robuste og langlivede. Godt rustet til daglig innsats. De seriemessige highlights som f. eks. sikkerhetsbomsystemet Multi Safe System (MSS), det massive kvalitets-helaluminiumsgulvet eller salkammeret som er innebygget i polyesterfronten oppfyller de høye kravene som hest og rytter stiller. Det tas også hensyn til optikken: Den enestående designen overbeviser over hele linjen og etterlater et flott inntrykk ved hver tur.



CHAMPION C
CHAMPION UNO C
CHAMPION ESPRIT C
 Page 29
 Side 29

CHAMPION R
BIG CHAMPION R
 Page 30
 Side 30

COMFORT
 Page 31
 Side 31



CHAMPION C

CHAMPION C

CHAMPION ESPRIT C

CHAMPION UNO C

The Champion C and Champion Esprit C for two horses and the Champion Uno C for one horse – or one mare with foal – are equipped with sturdy aluminium side walls (height 1500 mm) and the standard premium full aluminium floor.

Champion C og Champion Esprit C for to hester samt Champion Uno C for en hest – henholdsvis for en hoppe med føll – er utstyrt med robuste aluminiumsidevegger (1500mm høye) og standard høykvalitet minimumsgulv av aluminium.

At a glance / Kort oversikt

Number of horses / Antall hester	Champion C: Champion Esprit C: (or mare/foal) / (eller hoppe/føle) Champion Uno C:
Structure (Anodised aluminium)* Oppbygging (Eloksert aluminium)*	
Cover (Polyester)* (except Champion Esprit C) Hette (Polyester)* (unntatt Champion Esprit C)	Standard: Serie: Without surcharge: Uten tillegg i prisen: With surcharge: Med tillegg i prisen:
Chassis (standard) / Chassis (serie)	
Chassis (option, except Champion Esprit C) Chassis (optie, unntatt Champion Esprit C)	
Standard equipment (except Champion Esprit C) Serieutstyret (unntatt Champion Esprit C)	Multi Safe System**

Highlight of the standard equipment
Highlight blant serieutstyret



More comfort and durability thanks to the additional padding on the stable bars (1), the side padding (2), (except Champion Esprit C) and kick protection on both side walls (3), (except Champion Esprit C)
Bom-tilleggsbolstringen (1), sidebolstringen (2), (unntatt Champion Esprit C) og sparkebeskyttelsen på begge sideveggene (3), (unntatt Champion Esprit C) gir mer komfort og lang levetid



CHAMPION ESPRIT C



CHAMPION UNO C



Complete standard equipment Komplett serieutstyret	Page 32 – 33 Side 32 – 33
Accessories Tilbørsprogram	Page 66 – 68 Side 66 – 68

Some illustrations do not depict standard equipment.
Illustrasjonene tilsvarende delvis ikke serieutstyret.



CHAMPION R

CHAMPION R BIG CHAMPION R

The Champion R models have a polyester bow, which substantially increases the size of the front area, and a generously dimensioned tack room. With its interior length of 3415 mm, and an interior width of 1750 mm, the Big Champion R offers the discerning owner plenty of space.

Champion R-modellene har en polyesterfront, som er betydelig større foran og et stort salkammer. Big Champion R sørger ved hjelp av en indre lengde på 3415 mm og en indre bredde på 1750 mm for spesielt god plass.

At a glance / Kort oversikt

Number of horses / Antall bester	
Structure (Anodised aluminium)* Oppbygging (Eloksert aluminium)*	
	Standard: Serie:
Cover and bow (Polyester)* Hette og foran (Polyester)*	Without surcharge: Uten tillegg i prisen:
	With surcharge: Med tillegg i prisen:
Chassis (standard) / Chassis (serie)	
Chassis (accessories for Champion R, standard with Big Champion R) / Chassis (tilbehør ved Champion R, seriemessig for Big Champion R)	
Standard equipment / Serieutstyret	Multi Safe System**

Highlight of the standard equipment
Highlight blant serieutstyret



Features a tack room with storage compartment, extendable saddle racks, shovel, brush, mirror, door net, saddle cloth holder and interior lighting

Utstyrt med salkammer med hylle, uttrekkbare sadelholdere, spade, børste, speil, dørrnett, sjabrakkstativ og innebelysning



Complete standard equipment Komplett serieutstyret	Page 32 – 33 Side 32 – 33
Accessories Tilbehørsprogram	Page 66 – 68 Side 66 – 68

Some illustrations do not depict standard equipment.
Illustrasjonene tilsvarende delvis ikke serieutstyret.







COMFORT

COMFORT

 You will soon discover why we call this horse trailer “Comfort”. The sporty, dynamic shape and the comfort suspension chassis “CFFplus” guarantee an enjoyable driving experience. On top of this, the Comfort impresses with generous headroom for your horse plus plenty of storage space in the tack room. The set of features is completed by the Multi Safe System (MSS) among other things.

 Du merker med en gang hvorfor vi kaller denne bestebeggen for “Comfort”. Opplev ren kjøreglede ved den sportslig-dynamiske formen og Comfort-fjærings-understellet “CFFplus”. I tillegg overbeviser Comfort med mye plass i hodeområdet til hesten din og tallrike muligheter til å gjemme ting i salkammeret. Dette utstyret avrundes bl. a. med det Multi Safe System (MSS).

At a glance / Kort oversikt

Number of horses / Antall bester	
Standard: Serie:	
Without surcharge: Uten tillegg i prisen:	
Structure (Full Polyester)* Oppbygging (Hølpolyester)*	
With surcharge: Med tillegg i prisen:	
Chassis (standard) / Chassis (serie)	CFF^{PLUS}
Chassis (option) / Chassis (optie)	WCF^{PLUS}
Standard equipment / Serieutstyret	Multi Safe System** MSS

Highlight of the standard equipment Highlight blant serieutstyret



Features a tack room with storage compartment, extendable saddle racks, shovel, brush, mirror, door net, saddle cloth holder and interior lighting

Utstyrt med salkammer med hylle, uttrekkbare sadelholdere, spade, børste, speil, dørrnett, sjabrakkstativ og innebelysning



Complete standard equipment
Komplett serieutstyret

Page 32 – 33
Side 32 – 33

Accessories
Tilbehørsprogram

Page 66 – 68
Side 66 – 68

* More information on page 70 / Mer informasjon på side 70

** Safety stall bar system Multi Safe System / Sikkerhetsbom-systemet Multi Safe System

Some illustrations do not depict standard equipment.
Illustrasjonene tilsvarer delvis ikke serieutstyret.

Standard equipment.

Serieutstyret.

CHAMPION UNO C	1600 kg*	2760 mm	1830 mm	4490 mm	2300 mm	1300 mm	3100 mm	840 kg	(or mare/foal) (eller hoppe/fole)
CHAMPION ESPRIT C	2000 kg*	2760 mm	2200 mm	4500 mm	2300 mm	1650 mm	3100 mm	1135 kg	
CHAMPION C	2400 kg*	2760 mm	2200 mm	4500 mm	2300 mm	1650 mm	3100 mm	1502 kg	
CHAMPION R	2400 kg*	2760 mm	2200 mm	4500 mm	2300 mm	1650 mm	3280 mm	1497 kg	
BIG CHAMPION R	2400 kg*	2760 mm	2300 mm	4850 mm	2300 mm	1750 mm	3415 mm	1401 kg	
COMFORT	2400 kg*	2760 mm	2200 mm	4500 mm	2300 mm	1650 mm	3280 mm	1501 kg	

All rights to changes in design and equipment reserved. Weights and dimensions approximate; changes due to additional equipment possible.
 Vi forbeholder oss retten til å foreta konstruksjons- og utstyrsendringer. Vekt og mål er tilnærmet. De kan endre seg grunnet tilleggsutstyret.

* Curb weight reduction possible
 Reduksjon i samlet vekt mulig

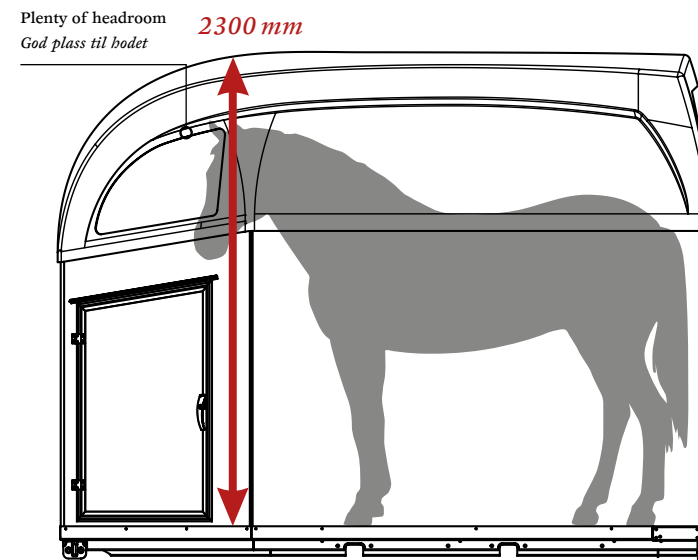
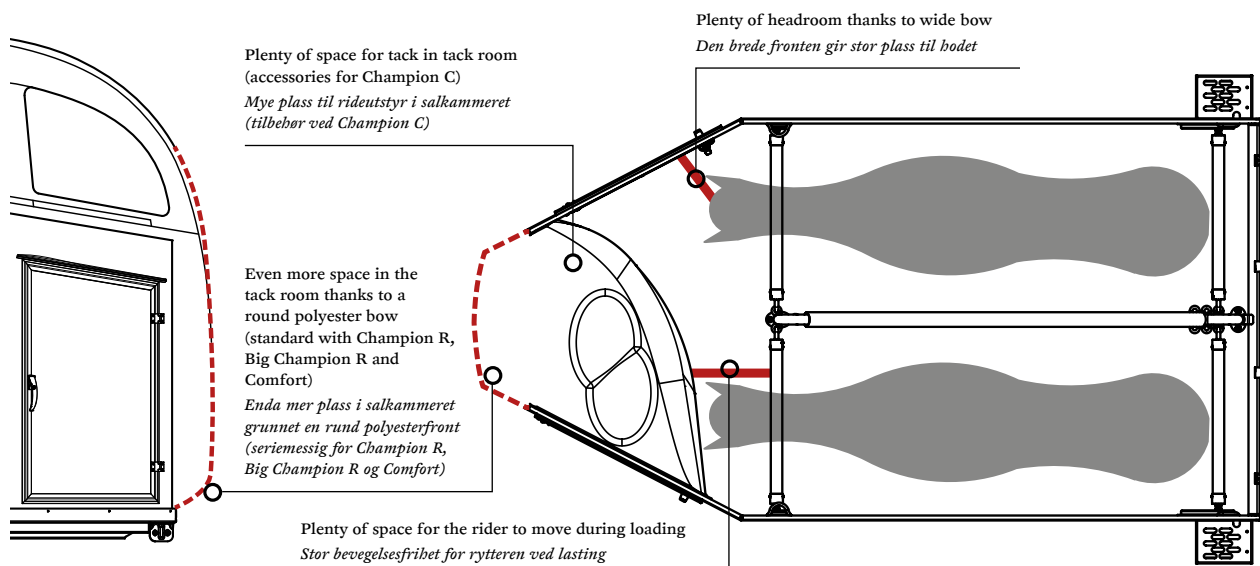

Chassis / Chassis



Perfect road holding thanks to lowered Comfort suspension chassis with wheel shock absorbers
Optimale kjøreegenskaper grunnet det senkede Comfort-fjæringssystemet med hjulstøtdempere

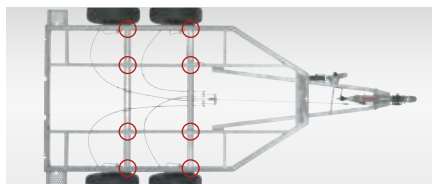

Made for heavy loads with axles bolted 8x to the longitudinal beam construction and a welded, hot-galvanized steel frame
Laget for høy belastning ved aksene som er skrudd fast til lengdedragerkonstruksjonen på 8 steder og sveisete, ildforsinkete stålrammer

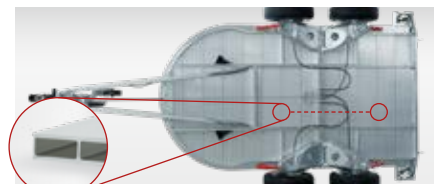

Robust and rot-proof thanks to the solid quality full aluminium floor (optional accessory on Comfort)
Robust og råtefri grunnet det massive kvalitetsaluminiumsgulv (tilleggsutstyr for Comfort)

Additional standard features:

- Bolted v-shaped towing bar with automatic jockey wheel
- Lockable cast coupling with padded comfort handle and soft-top
- Large illumination unit with reversing light and 13-pin plug
- Generously dimensioned 14" quality tyres (Champion Esprit C: 13")

Ytterligere serieutstyret:

- *Fastskrudd v-vognstang med autom. støttehjul*
- *Låsbar kobling med tildekket komforthåndtak og Soft-Top (startsperre)*
- *Stor belysningsenhet med ryggelys og 13-polet plugg*
- *Stordimensjonert 14" kvalitetsdekk (Champion Esprit C: 13")*

Structure / Ytre oppbygging



Attractive and with fresh air thanks to silver-metallic polyester top with large, dazzle-free opening windows for optimum air intake (Duo Esprit C with different window design)
Den sølv-metallic polyesterbetten med store, blende frie vippevinduer for optimalt luftinntak gjør den formskjønn og til et friskt pust (Duo Esprit C med avvikende vindusløsning)



Optimum interior atmosphere thanks to tarpaulin lift with integrated net**, also protects against rain and cold (Duo Esprit C, only tarpaulin lift)
*Optimalt romklima ved hjelp av rullgardinen med integrert nett**, beskytter mot regn og kulde (Duo Esprit C kun planlift)*

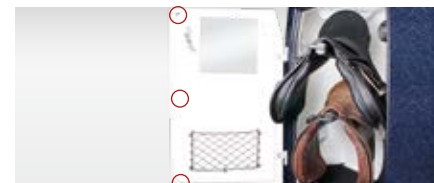

Safe closing thanks to 3-point door locking; a single master key locks all doors and the cast coupling (Duo Esprit C with non-lockable standard coupling)
Sikker låsing ved hjelp av 3-punkts-dørlås; en univer-salnøkkel låser alle dørene og koblingen (Duo Esprit C med standardkobling, ikke låsbar)

Additional standard features:

- Full polyester structure (Comfort) or anodised twin-walled aluminium structure (Champion)
- Stainless steel 304 bolts on structure
- Impact-resistant composite mudguards
- Lifting device on rear gate
- Number plate holder with 2 integrated steps
- Manoeuvring handle (except Champion Esprit C)
- Decor stripes on side wall with horse head as well as horse head decor on the tail gate (except Champion Esprit C)
- Rear strut closed (except Champion Esprit C)

Ytterligere serieutstyret:

- *Helpolyester-oppygging (Comfort) hhv. eloksert, dobbeltvegg aluminiums-oppygging (Champion)*
- *V2A-edelståltilskruing ved oppbyggingen*
- *Slagfast plast-skevettlapp*
- *Løfteutstyr på baklemmen*
- *Registreringskilt holder med to integrerte trinn*
- *Parkeringshåndtak (unntatt Champion Esprit C)*
- *Dekorasjonsstriper med bestebode på sideveggen som bestebode-dekorasjon på baklemmen (unntatt Champion Esprit C)*
- *Hekkehjelken er lukket (unntatt Champion Esprit C)*

Interior / Utstyr innvendig

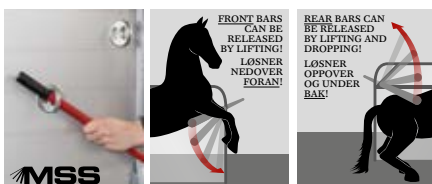

The height and longitudinally adjustable safety stall bar system (panic system) Multi Safe System*** for front and rear (Champion Uno C and Champion Esprit C with safety chain)
*Det høyde- og lengdejusterbare sikkerhetsbom-systemet (panikk-system) Multi Safe System*** for foran og bak (Champion Uno C og Champion Esprit C med små sikkerhetskjeder)*



Comfortable standing position thanks to additional padding on front stall bars (except Champion Esprit C)
Tilleggspolstringene på bommen foran gir behagelig stand (unntatt Champion Esprit C)



Comfort and durability thanks to side padding and kick protection (plastic) on both side walls (except Champion Esprit C, kick protection optional accessory on Comfort)
Sidepolstringen og sparkebeskyttelsen (plast) på begge side-veggene gir mer komfort og lang levetid (unntatt Champion Esprit C, sparkebeskyttelsen er tilleggsutstyr ved Comfort)

Additional standard features:

- Transparent PVC divider, flexible with PVC top section (except Champion Uno C and Champion Esprit C)
- Rubber matting with anti-slip structure, glued and sealed
- Rubber liner on tail gate with special cross step bars, run-off duct, and side stops
- Calming blue LED transport light with separate switch – can be switched over from white to blue
- Champion R, Big Champion R and Comfort: Tack room with storage compartment, extending saddle racks with adjustable height, plastic shovel, telescopic brush, mirror, door net, saddle cloth holder and interior lighting

Ytterligere serieutstyret:

- *Gjennomiktig PVC-skillevegg, fleksibel med PVC-overdel (unntatt Champion Uno C og Champion Esprit C)*
- *Gummigulv med sklisikkert tekstilstruktur, fastlimt og forseglet*
- *Gummibelegg på baklemmen med spesial-tverrlist, avløpsrenne og sidestopp*
- *Beroligende, blått LED-transportlys med separat bryter – mulig å skifte fra hvitt til blått lys*
- *Champion R, Big Champion R og Comfort: Salkammer med hylle, uttrekkbare og høydejusterbare sadelholdere, plastsjape, teleskopborste, speil, dørrnett, sjabakkstativ og innebelysning*

 The Master family.
 *Master-familien.*



**PURE FASCINATION:
OUR MASTERPIECE.**

The Master family still sparks enthusiasm with its elegant front-to-rear styling and exciting, sporty appearance. It even has single-wheel polyester mudguards and side strut covers as a standard feature. The luxurious features, the excellent driving comfort due to the world-class “WCFplus” chassis to automotive standards – all part of the package – and the generous dimensions all do justice to the design. – Genuine masterpieces!

**REN FASCINASJON:
VÅRT UNDERVERK.**

Med sin gjennomførte linjeføring sørger Master-familien fremdeles for begeistring, den er både sportslig, elegant og fascinerende. Den glitrer til og med med seriemessige enkeltb-julskvettlapper og sidebjelkedekser i polyester. Det eksklusive serieutstyret, den fremragende kjørekomforten takket være det seriemessige World-Class-chasset “WCFplus” som holder bilstandard og den gode plassen innvendig kompletterer designinntrykket. – Et ekte mesterverk!



MASTER
Page 35
Side 35



BIG MASTER
BIG MASTER L
Page 36
Side 36





GRAND MASTER
Page 37
Side 37



MASTER

MASTER

 Timeless elegance combined with exclusive features and generous dimensions: The Master leaves nothing to be desired! In addition to the polyester single-wheel mudguards and side strut covers, the Master also offers driving and suspension comfort according to the automotive standard with the world-class “WCFplus” chassis – as standard.

 *Tidløs elegance kombinert med eksklusivt utstyr og stordimensjonerte mål: Med Master får man alt man ønsker seg! I tillegg til enkeltskvettlapper og sidehjelkedeksler i polyester tilbyr Master også en kjøre- og fjæringskomfort som likner bilens standard ved hjelp av World-Class-chassiset “WCFplus” seriemessig.*

 At a glance /  Kort oversikt

Number of horses / Antall bester



Standard:
Serie:



Without surcharge:
Uten tillegg i prisen:



Structure (Full Polyester)*
Oppbygging (Helpolyester)*

With surcharge:
Med tillegg i prisen:



Chassis (standard) / Chassis (serie)



Standard equipment / Seriestyret

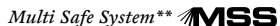

Highlight of the standard equipment
Highlight blant seriestyret



Even more driving comfort thanks to the World Class chassis to automotive standards with wheel shock absorbers with single-wheel suspension and screw-type suspension
Enda mer kjørekomfort grunnet World-Class-chassiset laget etter bilstandard med hjulstøtdempere med enkelthjuloppbening og skrueffjering



Complete standard equipment
Komplett seriestyret
Accessories
Tilbørsprogram

Page 38 - 39
Side 38 - 39
Page 66 - 68
Side 66 - 68

* More information on page 70 / Mer informasjon på side 70

** Safety stall bar system Multi Safe System / Sikkerhetsbom-systemet Multi Safe System

Some illustrations do not depict standard equipment.
Illustrasjonene tilsvarer delvis ikke seriestyret.



BIG MASTER

BIG MASTER

BIG MASTER L

The Big Master has particularly generous dimensions with an interior length of 3,600 mm and an interior width of 1,750 mm. The Big Master L convinces with even more space. The standard equipment includes a large tack room and the world-class chassis "WCFplus" to automotive standard.

I Big Master med innvendig lengde på 3 600 mm og innvendig bredde på 1 750 mm, ble det lagt spesielt stor vekt på store rom. Big Master L overbeviser med enda mer plass. Standardutstyr er bl.a. et stort salkammer og World Class-chassiset «WCFplus», som oppfyller bilstandard.

At a glance / Kort oversikt

Number of horses / Antall bester	
Standard:	
Serie:	
Without surcharge: Uten tillegg i prisen:	
Structure (Full Polyester)* Oppbygging (Hølpolyester)*	
With surcharge: Med tillegg i prisen:	
Chassis (standard) / Chassis (serie)	WCF[®] PLUS
Standard equipment / Seriestyret	Multi Safe System**

Highlight of the standard equipment Highlight blant seriestyret



Even more driving comfort thanks to the World Class chassis to automotive standards with wheel shock absorbers with single-wheel suspension and screw-type suspension
Enda mer kjørekomfort grunnet World-Class-chassiset laget etter bilstandard med hjulstøtdempere med enkelthjuloppbenging og skrueffjering



BIG MASTER L **NEW / NY**



	Complete standard equipment Komplett seriestyret	Page 38 - 39 Side 38 - 39
	Accessories Tilbehørsprogram	Page 66 - 68 Side 66 - 68

Some illustrations do not depict standard equipment.
Illustrasjonene tilsvarer delvis ikke seriestyret.



GRAND MASTER





GRAND MASTER

 A true space saver: The Grand Master offers plenty of extra space for horse and rider. The two models SKA (tack room accessible from outside) and SR (large, walk-in tack room), shine not only with their distinctive design, they also offer plenty of highlights, e.g. the calming blue LED transport light or the extremely variable centre-post partition wall system.

 *Et virkelig plassmirakel: Grand Master tilbyr best og rytter ekstra mye plass. De to modellene SKA (salkammer tilgjengelig fra utsiden) og SR (stort salkammer man kan gå inn i), utmerker seg ikke bare med unik design, men også mange nyttige detaljer som beroligende, blått LED-transportlys eller svært fleksibelt midtstolpe-skilleveggsystem.*

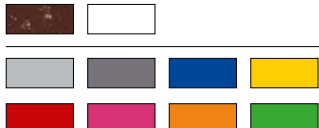

At a glance / Kort oversikt

Number of horses / Antall hester	
Standard: Serie:	
Structure (Full Polyester)* Oppbygging (Hølpolyester)*	Without surcharge: Uten tillegg i prisen:  With surcharge: Med tillegg i prisen: 
Chassis (standard) / Chassis (serie)	
Standard equipment / Seriestyret	Multi Safe System** 

Highlight of the standard equipment Highlight blant seriestyret



Tack room accessible from inside and outside with a full-height access door inside on the Grand Master SR (Grand Master SKA with tack room, see Page 38)

Salkammer tilgjengelig fra innsiden og utsiden, med normalbøy innvendig inngangsdør på Grand Master SR (Grand Master SKA med sadelkammer, se side 38)



Complete standard equipment Komplett seriestyret	Page 38 - 39 Side 38 - 39
Accessories Tilbørsprogram	Page 66 - 68 Side 66 - 68



















* More information on page 70 / Mer informasjon på side 70

** Safety stall bar system Multi Safe System / Sikkerhetsbom-systemet Multi Safe System

Some illustrations do not depict standard equipment.
Illustrasjonene tilsvarende delvis ikke seriestyret.

🇬🇧 Standard equipment.

🇳🇴 Seriestyret.

									
 MASTER	2400 kg*	2770 mm	2220 mm	4515 mm	2350 mm	1650 mm	3260 mm	1461 kg	
 BIG MASTER	2400 kg*	2720 mm	2320 mm	4950 mm	2300 mm	1750 mm	3600 mm	1393 kg	
 BIG MASTER L	2400 kg	2780 mm	2310 mm	5260 mm	2300 mm	1750 mm	3900 mm	1238 kg	
 GRAND MASTER SKA	2700 kg	2780 mm	2310 mm	5260 mm	2300 mm	1750 mm	3900 mm	1541 kg	
 GRAND MASTER SR	2700 kg	2780 mm	2310 mm	5260 mm	2300 mm	1750 mm	3900 mm	1499 kg	

All rights to changes in design and equipment reserved. Weights and dimensions approximate; changes due to additional equipment possible. *Vi forbeholder oss retten til å foreta konstruksjons- og utstyrsendringer. Vekt og mål er tilnærmet. De kan endre seg grunnet tilleggsutstyret.*

* Curb weight reduction possible. *Reduksjon i samlet vekt mulig*

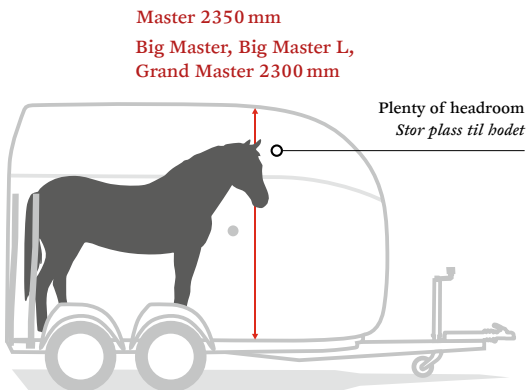

Master tack room / Salkammer Master



With extending, height-adjustable saddle racks, one storage compartment, plastic shovel, telescopic brush, mirror, door net, saddle cloth holder and interior lighting

Med uttrekkbare og høydejusterbare sadelholdere, en hylle, plastspade, teleskopbørste, speil, dørrnett, sjabrakkstativ og innebelysning

Big Master and Grand Master SKA tack room / Salkammer Big Master und Grand Master SKA

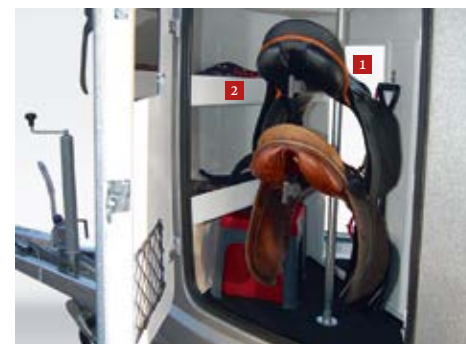

Interior also accessible through an interior second door (1) (equipment same as Master tack room with additional storage compartment (2) and 2 mountable feeding troughs)

Dobbelt tilgjengelig grunnet en ekstra innvendig dør (1) til innerommet (utstyr som ved Master-salkammeret med ytterligere hylle (2) og to førbokser som kan henges inn)

Grand Master SR tack room / Salkammer Grand Master SR



Plenty of space for riding equipment with the tack room accessible from inside and outside with a full-height access door inside

Mye plass til rideutstyr i salkammeret som er tilgjengelig fra innsiden og utsiden, utstyrt med normalhøy innvendig inngangsdør.

Chassis / Chassis



Even more driving comfort due to the World Class chassis to automotive standards
Enda mer kjørekomfort grunnet World-Class-chassiset laget etter bilstandard

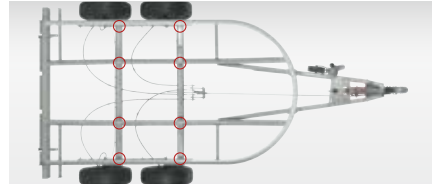

Made for heavy loads with axles bolted 8x to the longitudinal beam construction and a welded, hot-galvanised steel frame
Laget for høy belastning ved aksene som er skrudd fast til lengdedragerkonstruksjonen på 8 steder og sveisete, ildforsinkete stålrammer

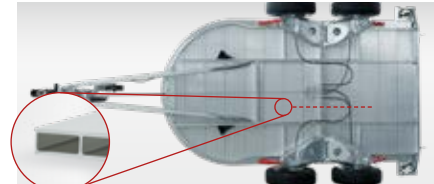

Robust and rot-proof thanks to the solid quality full aluminium floor
Robust og råtefri grunnet det massive kvalitetsaluminiumsgulv

Additional standard features:

- Bolted v-shaped towing bar with automatic jockey wheel
- Lockable cast coupling with padded comfort handle and soft-top
- Large illumination unit with reversing light and 13-pin plug
- Generously dimensioned quality tyres

Ytterligere serieutstyret:

- *Fastskrudd v-vognstang med autom. støttehjul*
- *Låsbar kobling med tildekket komforthåndtak og Soft-Top (startsperre)*
- *Stor belysningsenhet med ryggelys og 13-polet plugg*
- *Stordimensjonert kvalitetsdekk*

Structure / Ytre oppbygging



Good ventilation thanks to large, dazzle-free pop-out windows (Grand Master with different window design)
God ventilasjon gjennom de store vippevindueene som vippes bakover og som er blendefrie (Grand Master med avvikende vindusløsning)



Optimum interior atmosphere thanks to tarpaulin lift with integrated net** (also protects against rain and cold)
*Optimalt romklima ved hjelp av rullgardinen med integrert nett** (beskytter mot regn og kulde)*



Visual highlight with polyester covers on the lateral struts and polyester single-wheel mudguards in superstructure colour
Optisk highlight grunnet sidebjelkebeskyttelse i polyester og enkeltjulskvettlapp i polyester i oppbyggingsfarge

Additional standard features:

- Anodised, dual-wall aluminium structure with polyester top and bow
- Tall side walls 2100 mm
- Stainless steel 304 bolts on structure
- Impact-resistant composite mudguards
- Lifting device on rear gate
- Number plate holder with 2 integrated steps
- Decor stripes on side wall with horse head as well as horse head decor on the tail gate
- Rear strut closed
- Lockable doors with 3-point door locking system

Ytterligere serieutstyret:

- *Eloksert, dobbeltvegg aluminiumsoppbygging med polyesterhette og -front*
- *Høy kantvegg 2100 mm*
- *V2A-edelståltilskruing ved oppbyggingen*
- *Slagfast plast-skvettlapp*
- *Løfteutstyr på baklemmen*
- *Registreringskiltbolder med to integrerte trinn*
- *Dekorasjonsstriper med bestebode på sideveggen og bestebode-dekorasjonen på baklemmen*
- *Hekkbjelken er lukket*
- *Låsbare dører med 3-punkts-dørlås*

Interior / Utstyr innvendig

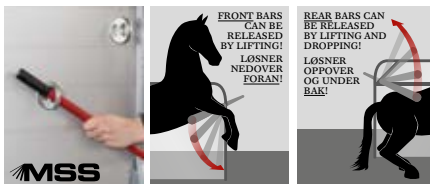

The height and longitudinally adjustable safety stall bar system (panic system) Multi Safe System*** for front and rear
*Det høyde- og lengdejusterbare sikkerhetsbomsystemet (panikkssystem) Multi Safe System*** for foran og bak*



Comfortable standing position thanks to additional padding on front stall bars
Tilleggsplstringene på bommen foran gir behagelig stand



Comfort and durability thanks to side padding and kick protection (composite) on both side walls
Sidepolstringen og sparkebeskyttelsen (plast) på begge sideveggene gir økt komfort og lang levetid

Additional standard features:

- Transparent PVC divider, flexible with PVC top section
- Rubber matting with anti-slip structure, glued and sealed
- Rubber liner on tail gate with special cross step bars, run-off duct, and side stops
- Calming blue LED transport light with separate switch - can be switched over from white to blue
- Wear mat
- Feed troughs

Ytterligere serieutstyret:

- *Gjenomsiktig PVC-skillevegg, fleksibel med PVC-overdel*
- *Gummigulv med sklisikkert tekstilstruktur, fastlimt og forseglet*
- *Gummibelegg på baklemmen med spesial-tverrlister, avløpsrenne og sidestopp*
- *Beroligende, blått LED-transportlys med separat bryter - mulig å skifte fra hvitt til blått lys*
- *Slitematte*
- *To førbokser*

 **The Portax family.**
 *Portax-familien.*



**CONVINCING:
 MORE SPACE. MORE COMFORT.**

The Portax family convinces with maximum comfort for horse and rider. All models combine super-easy handling and excellent design with plenty of space. This makes the Portax E, K, and SKA perfect companions in the everyday routine of riders. In particular the Portax L models are characterised by the extra room they offer. Enjoy even more luxurious space in the models Big Portax and Mega Portax.

**OVERBEVISENDE:
 MER PLASS. MER KOMFORT.**

Portax-familien overbeviser med maksimal komfort for best og rydder. Alle modeller forener kjempelett håndtering og fremragende design sammen med romslig plass. Slik blir Portax E, K og SKA til perfekte ledsakere for rytterens dagligliv. Portax L modellen utmerker seg spesielt med det tydelig utvidede plasstilbudet. Enda mer luksuriøs plass finner du i modellene Big Portax og Mega Portax.



PORTAX E, K, SKA
 Page 41 - 43
 Side 41 - 43

PORTAX L E, K, SKA, SR
 Page 46 - 49
 Side 46 - 49



BIG PORTAX
 Page 52
 Side 52





MEGA PORTAX
 Page 53
 Side 53













PORTAX E

PORTAX

 Space miracle with a convincing design:
The Portax E, K, and SKA offer plenty of space for horse and rider. The equipment highlights provided as a standard make the models of the Portax series perfect and multi-talented companions. To get an impression of the wide range of options, just turn the page!

 *Et ekte plassmirakel, overbevisende design:
Portax E, K og SKA har mye plass både for hest og rytter. Standard viktig utstyr gjør Portax-modellene til ekte multitalenter. Oppdag selv de mangfoldige mulighetene på de neste sidene, Bla videre!*

 At a glance /  Kort oversikt

Number of horses / Antall hester	
Structure (Anodised aluminium)* Oppbygging (Eloksert aluminium)*	
	Standard: Serie: 
	Without surcharge: Uten tillegg i prisen: 
Cover and bow (Polyester)* Hette og foran (Polyester)*	 
	With surcharge: Med tillegg i prisen: 
	
Chassis (standard) / Chassis (serie)	
Standard equipment / Serieutstyret	Multi Safe System** 

Highlight of the standard equipment
Hightlight blant serieutstyret



Even more driving comfort thanks to the World Class chassis to automotive standards with wheel shock absorbers with single-wheel suspension and screw-type suspension
Enda mer kjørekomfort grunnet World-Class-chassiset laget etter bilstandard med hjulstøtdempere med enkelthjuloppbening og skrueffjering



PORTAX K

PORTAX SKA

	Complete standard equipment Komplett serieutstyret	Page 44 - 45 Side 44 - 45
	Accessories Tilbørersprogram	Page 66 - 68 Side 66 - 68

* More information on page 70 / Mer informasjon på side 70

** Safety stall bar system Multi Safe System / Sikkerhetsbom-systemet Multi Safe System

Some illustrations do not depict standard equipment.
Illustrasjonene tilsvarer delvis ikke serieutstyret.

PORTAX E

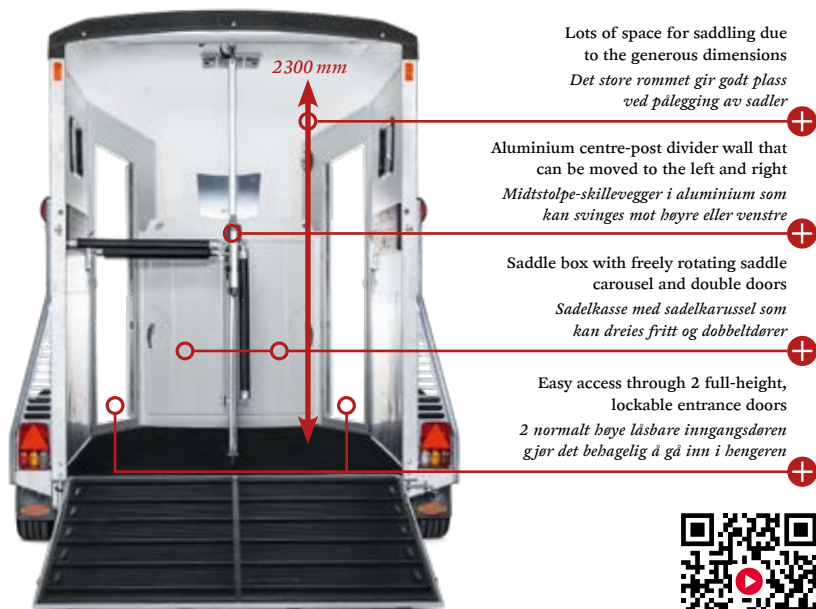

Lots of space for saddling due to the generous dimensions

Det store rommet gir godt plass ved pålegging av sadler

Aluminium centre-post divider wall that can be moved to the left and right

Midtstolpe-skillevægger i aluminium som kan svinges mot høyre eller venstre

Saddle box with freely rotating saddle carousel and double doors

Sadelkasse med sadelkarussell som kan dreies fritt og dobbeltdører

Easy access through 2 full-height, lockable entrance doors

2 normalt høye låsbare inngangsdøren gjør det beagelig å gå inn i bengeren



Highlights of the Portax E / *Portax E sine highlights*

PORTAX K



Lots of space for saddling due to the generous dimensions

Det store rommet gir godt plass ved pålegging av sadler

Easy unloading with the wide, extra-long front unloading hatch

Den brede og ekstra lange losselemmen foran gjør det lett å gå ut av bengeren

Highlights of the Portax K / *Portax K sine highlights*



Freely rotating saddle carousel with more space in the tack room due to wide bow
Fritt dreibar sadelkarussell med mer plass i sadelkammeret grunnet den brede fronten



Tack room accessible from the inside and generous space allowance with an interior height of 2300 mm

Sadelkammer som kan nås fra innsiden og stordimensjonerte rom med en innvendig høyde på 2300 mm



Saddle box in bow for english and western saddles with plastic shovel, telescopic brush and bridle pegs

Sadelkasse i fronten for engelske sadler og westernsaddler med plastsjåpe, teleskopbørste og trinsekroker



Wide, extra-long front unloading hatch with rubber coating and "gas spring" lifting device
Bred og ekstra lang losselem med gummibelegg og løfteinnretning "Støtdemper"

PORTAX SKA

Lots of space for saddling due to the generous dimensions
Det store rommet gir godt plass ved pålegging av sadler

The tack room is accessible from inside and outside, with swivelling saddle rack for English and western saddles

Sadelkammer tilgjengelig innenfra og utenfra med svingbar sadelholder for engelsk sadel og western-sadel

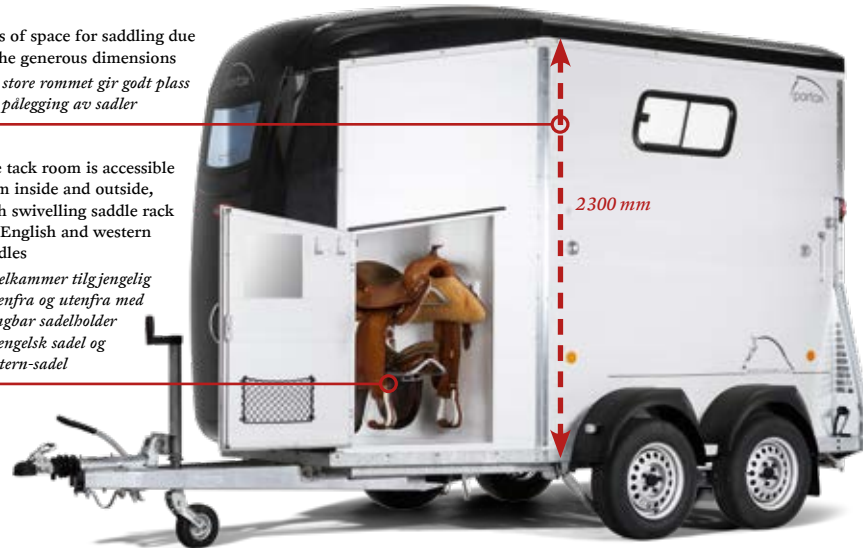

Highlights of the Portax SKA / *Portax SKA sine highlights*



Fast and comfortable access to the tack room from the inside and the outside. With swivelling saddle rack for English saddles. The tack room is equipped with plastic shovel, telescopic broom, bridle pegs, door net, and mirror.

Enkel og rask tilgang til sadelkammeret ved tilgang innenfra og utenfra, med svingbar holder for engelsk sadel. Sadelkammeret er utstyrt med plastbøtte, teleskopbørster, kroker, dørmatt og speil.

Highlights of the Portax standard equipment / *Highlights ved Portax seriestyr*



Standard tail gate/1-wing door combination. As a result, the Portax can also be loaded from a forklift truck.

Seriemessig baklem/1-fløyeldørskombinasjon. Slik kan Portax også lastes med en gaffeltruck.



Easy loading for horse & rider due to the ability to move the aluminium centre post divider wall to the left or right

Enkel lossing for best og rytter ved hjelp av en midtstolpeskillevegg i aluminium som kan svinges både til høyre og til venstre

Highlights of the Portax range of accessories / *Highlights i Portax tilbehørsprogram*

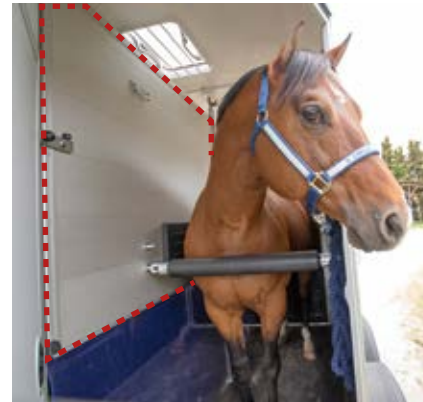

Safe transport with an aluminium centre post partition wall that can be moved to the left and right with an integrated head partition wall (accessory)

Sikker transport ved hjelp av en midtstolpe-skillevegg i aluminium med integrert hodeskillevegg (tilleggsutstyr) som kan svinges til høyre eller til venstre













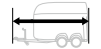

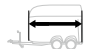
Lockable aluminium tail gate (available for all Portax models, standard tarpaulin lift with integrated net)

Låsbar baklem i aluminium (tilgjengelig for alle Portax-modeller, seriemessig rullgardin med integrert nett nett)

🇬🇧 Standard equipment.

🇳🇴 Seriestyret.

									
 PORTAX SKA	2400 kg	2815 mm	2350 mm	4725 mm	2300 mm	1750 mm	3495 mm	1321 kg	
 PORTAX E	2400 kg	2815 mm	2350 mm	4725 mm	2300 mm	1750 mm	3495 mm	1321 kg	
 PORTAX K	2400 kg	2815 mm	2350 mm	4725 mm	2300 mm	1750 mm	3495 mm	1321 kg	

All rights to changes in design and equipment reserved. Weights and dimensions approximate; changes due to additional equipment possible.
Vi forbeholder oss retten til å foreta konstruksjons- og utstyrsendringer. Vekt og mål er tilnærmet. De kan endre seg grunnet tilleggsutstyret.

* Curb weight reduction possible
Reduksjon i samlet vekt mulig

Portax SKA / Portax SKA

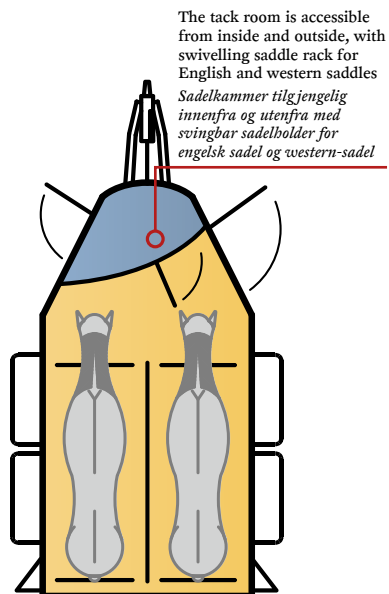

Portax K / Portax K

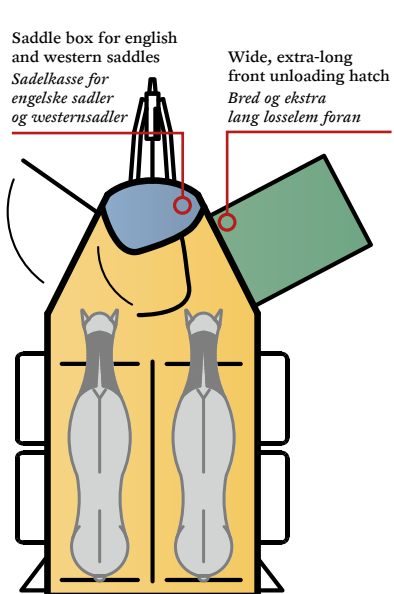

Portax E / Portax E

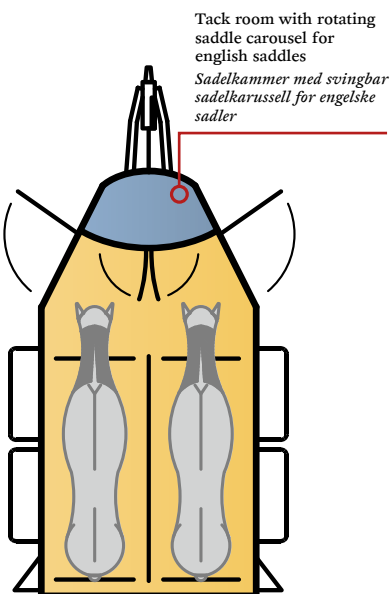

Portax SKA, E and K / Portax SKA, E og K

A lot of head room thanks to an interior height of 2300 mm
Den innvendige høyden på 2300 mm gir svært god bodefrihet

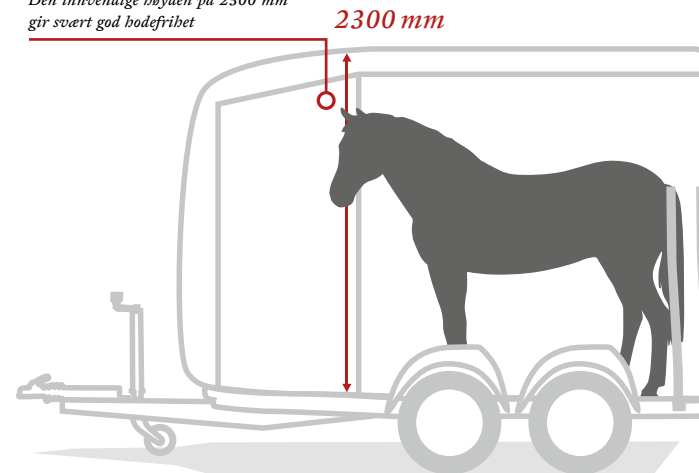

Chassis / Chassis



Even more driving comfort due to the World Class chassis to automotive standards
Enda mer kjørekomfort grunnet World-Class-chassiset laget etter bilstandard

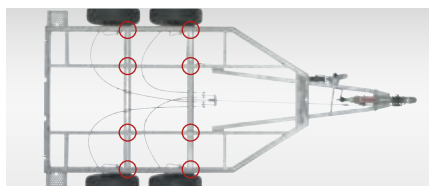

Made for heavy loads with axles bolted 8x to the longitudinal beam construction and a welded, hot-galvanised steel frame
Laget for høy belastning ved aksene som er skrudd fast til lengdedragerkonstruksjonen på 8 steder og sveisete, ildforsinkete stålrammer



Safe hitching and unhitching thanks to lockable cast coupling with padded comfort handle and soft top (drive-off protection)
Sikker til og frakobling ved hjelp av låsbare koblinger med tildekket komforthåndtak og Soft-Top (startspærre)

Additional standard features:

- Bolted v-shaped towing bar with automatic jockey wheel
- Large illumination unit with reversing light and 13-pin plug
- Generously dimensioned quality tyres
- Quality solid aluminium floor

Ytterligere serieutstyret:

- Fastskrudd v-vognstang med autom. støttehjul
- Stor belysningsenhet med ryggelys og 13-polet plugg
- Stordimensjonert kvalitetsdekk
- Kvalitets-belaluminiumsgulv

Structure / Ytre oppbygging



Broad range of applications due to the standard tail gate/1-wing door combination
Mangfoldige bruksmuligheter ved den seriemessige baklemmen/1-fløyeldørkombinasjon



Optimum interior atmosphere thanks to tarpaulin lift with integrated net** (also protects against rain and cold)
*Optimalt romklima ved hjelp av rullgardinen med integrert nett** (beskytter mot regn og kulde)*



Optimum ventilation with the sliding windows at the side, panorama windows in the polyester bow and roof vent
Skyvøvindu på siden, panoramavindu i polyesterfronten og takvifte gir et optimalt romklima

Additional standard features:

- Anodised, dual-wall aluminium structure with polyester top and bow
- Tall side walls 2100 mm
- Stainless steel 304 bolts on structure
- Impact-resistant composite mudguards
- Lifting device on rear gate
- Number plate holder with 2 integrated steps
- Decor stripes on side wall with horse head as well as horse head decor on the tail gate
- Rear strut closed
- Lockable doors with 3-point door locking system

Ytterligere serieutstyret:

- Elokert, dobbeltvegg aluminiumsoppbygging med polyesterhette og -front
- Høy kantvegg 2100 mm
- V2A-edelståltilskruing ved oppbyggingen
- Slagfast plast-skevettlapp
- Løfteutstyr på baklemmen
- Registreringskilttholder med to integrerte trinn
- Dekorasjonsstriper med bestebode på sideveggen og bestebode-dekorasjonen på baklemmen
- Hekkbjelken er lukket
- Låsbare dører med 3-punkts-dørlås

Interior / Utstyr innvendig



The height and longitudinally adjustable safety stall bar system (panic system) Multi Safe System*** for front and rear

*Det høyde- og lengdejusterbare sikkerhetsbomsystemet (panikkssystem) Multi Safe System*** for foran og bak*



Comfort and durability thanks to additional stable bar padding (1), side padding (2) and kick protection (composite) (3)

Tilleggsbolstring på bommene (1), sidebolstring (2) og sparkebeskyttelse (plast) (3) gir økt komfort og lang levetid



Freely rotating saddle carousel with more space in the tack room due to wide bow, Portax SKA, tack room accessible from the outside as a standard

Fritt dreibar sadelkarussell med mer plass i sadelkammeret grunnet den brede fronten, Portax SKA standard med sadlekammer tilgjengelig fra utsiden

Additional standard features:

- Transparent PVC divider, flexible with PVC top section
- Aluminium centre post partition wall that can be moved to the left and right
- Rubber matting with anti-slip structure, glued and sealed
- Rubber liner on tail gate with special cross step bars, run-off duct, and side stops
- Calming blue LED transport light with separate switch - can be switched over from white to blue

Ytterligere serieutstyret:

- Gjennomskiktig PVC-skillevegg, fleksibel med PVC-overdel
- Midstolpe-skillevegg i aluminium som kan svinges mot høyre eller venstre
- Gummigulv med sklisikkert tekstilstruktur, fastlimt og forseglet
- Gummibelegg på baklemmen med spesial-tverrlistor, avløpsrenne og sidestopp
- Beroligende, blått LED-transportlys med separat bryter - mulig å skifte fra hvitt til blått lys



PORTAX L SR





PORTAX L K



PORTAX L SKA

PORTAX L















 Added comfort, premium quality, and above all plenty of space for the various requirements of horse and rider. Every aspect of the new Portax L convinces. To find inspiration from the variable space concepts and to discover the numerous special features of the Portax L models, just turn the page!

 *Mer komfort, førsteklasses kvalitet og frem for alt ganske mye plass for de mangfoldige behovene til hest og rytter. Den nye Portax L overbeviser over hele linjen. La deg inspirere av de variable romkonseptene, og oppdag de mangfoldige særegenhetene til Portax L modellene på de neste sidene. Bla videre!*



PORTAX L E

At a glance / Kort oversikt

Number of horses / Antall hester	
Structure (Anodised aluminium)* Oppbygging (Eloksert aluminium)*	
	Standard: Serie: 
Cover and bow (Polyester)* Hette og foran (Polyester)*	Without surcharge: Uten tillegg i prisen:     With surcharge: Med tillegg i prisen:        
Chassis (standard) / Chassis (serie)	WCF[®] PLUS
Standard equipment / Serieutstyret	Multi Safe System** MSS

* More information on page 70 / Mer informasjon på side 70

** Safety stall bar system Multi Safe System / Sikkerhetsbom-systemet Multi Safe System

Highlight of the standard equipment Hightlight blant serieutstyret



Even more driving comfort thanks to the World Class chassis to automotive standards with wheel shock absorbers with single-wheel suspension and screw-type suspension
Enda mer kjørekomfort grunnet World-Class-chassiset laget etter bilstandard med hjulstøtdempere med enkelthjuloppbening og skrueffjering

	Complete standard equipment Komplett serieutstyret	Page 50 - 51 Side 50 - 51
	Accessories Tilbehørsprogram	Page 66 - 68 Side 66 - 68

Some illustrations do not depict standard equipment.
Illustrasjonene tilsvarer delvis ikke serieutstyret.

PORTAX L SR



- 1** Lots of space for saddling due to the generous dimensions / *God plass til å sale på, takket være romslige plassforhold*
- 2** Much room for getting in and out of the trailer thanks to the aluminium centre-post divider wall than can be moved to the left and right / *God plass ved inn- og utstigning takket være svingbar aluminium midtstolper/skillevegg*
- 3** Easy access through 3 full-height, lockable entrance doors (optionally with 4th door on the left, seen in travel direction) / *Enkel innstigning på grunn av 3 mannsbøye, låsbare inngangsdører (som ekstrautstyr med 4. dør til venstre i kjøreretningen)*
- 4** A divider wall separates the tack room from the horse compartment (optionally available with a passage door) plus 2 shelves, whip stowing tube, bridle pegs, nets, 2 mirrors, and bootjack / *Sadelkammeret er adskilt fra hesterommet med en mellomvegg (valgfritt med gjennomgangsdør) plus 2 hyller, ridepiskstativ, kroker, 2 speil og støvelknekt*
- 5** Walk-in tack room with swivelling saddle rack for English and western saddles / *Tilgjengelig sadelkammer med svingbar sadelholder for engelsk sadel og western-sadel*
- 6** Seats / *Sittemulighet*

PORTAX L SKA

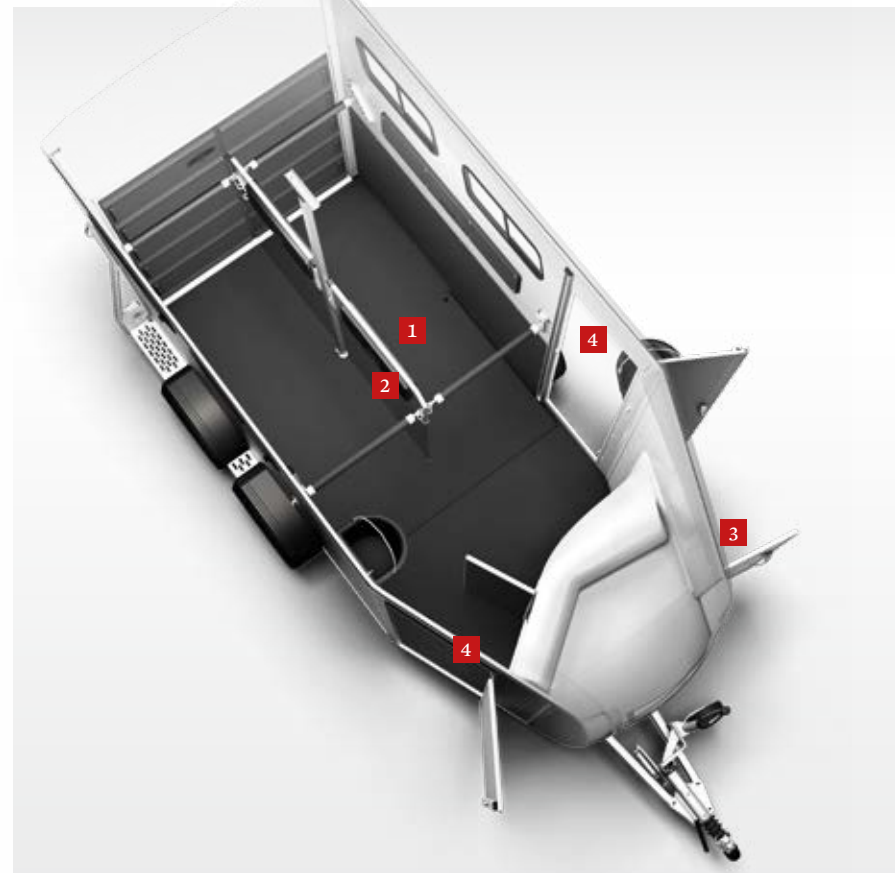

- 1** Lots of space for saddling due to the generous dimensions / *God plass til å sale på, takket være romslige plassforhold*
- 2** Much room for getting in and out of the trailer thanks to the aluminium centre-post divider wall than can be moved to the left and right / *God plass ved inn- og utstigning takket være svingbar aluminium midtstolper/skillevegg*
- 3** Tack room is accessible from inside and outside, with swivelling saddle rack for English and western saddles / *Sadelkammeret er tilgjengelig innenfra og utenfra med svingbar sadelholder for engelsk sadel og western-sadel*
- 4** Easy access through 2 full-height, lockable entrance doors / *Enkel innstigning på grunn av 2 mannsbøye, låsbare inngangsdører*

PORTAX L E

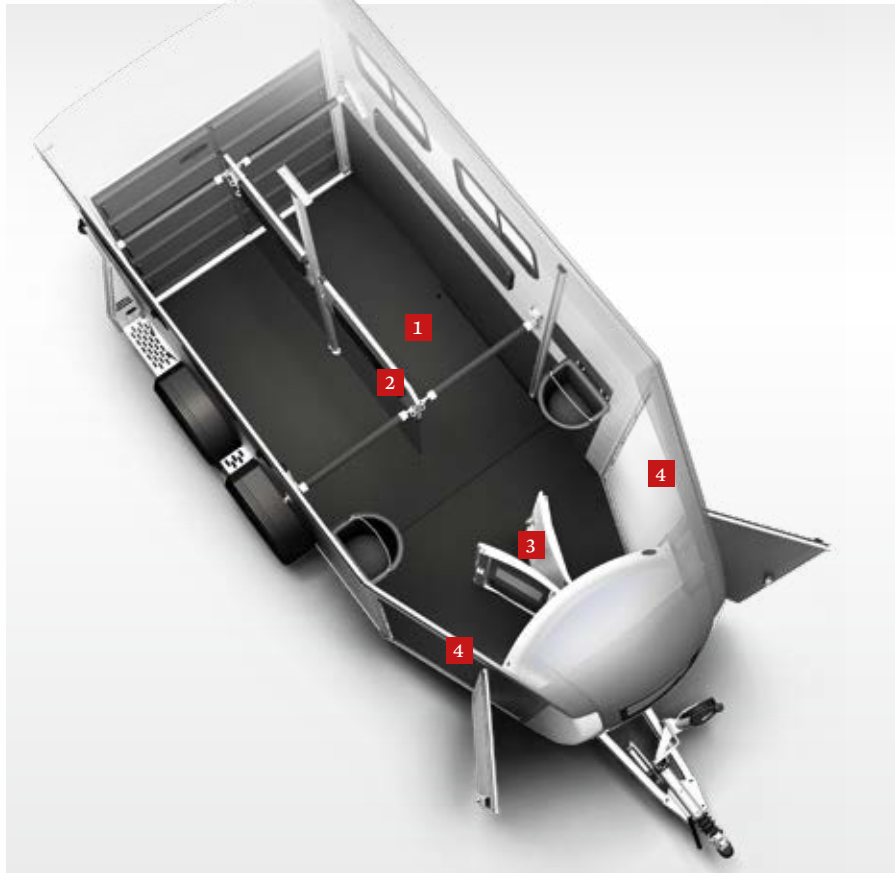

- 1** Lots of space for saddling due to the generous dimensions / *God plass til å sale på, takket være romslige plassforhold*
- 2** Much room for getting in and out of the trailer thanks to the aluminium centre-post divider wall that can be moved to the left and right / *God plass ved inn- og utstigning takket være svingbar aluminium midtstolper/skillevegg*

- 3** Comfortable access to the tack room from each side due to 2 doors and the freely rotating saddle carousel / *Komfortabel tilgang til sadelkammeret fra hver side gjennom 2 dører og fritt deribar sadelkarusell*
- 4** Easy access through 2 full-height, lockable entrance doors / *Enkel innstigning på grunn av 2 mannsbøye, låsbare inngangsdører*

PORTAX L K

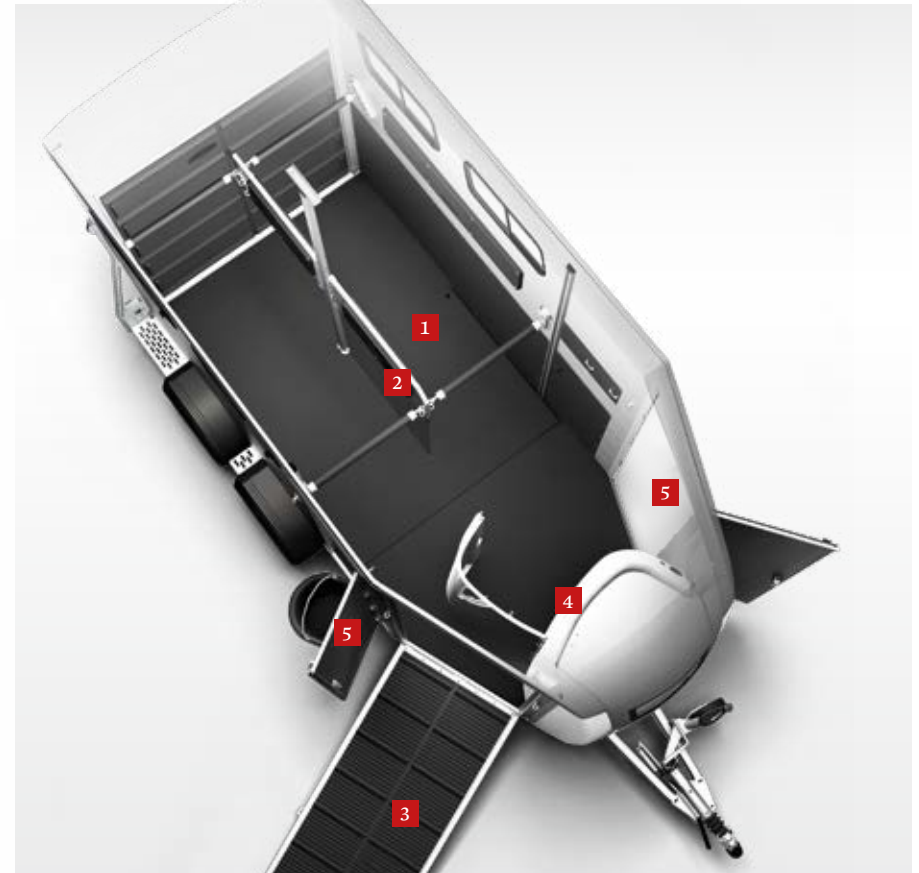

- 1** Lots of space for saddling due to the generous dimensions / *God plass til å sale på, takket være romslige plassforhold*
- 2** Much room for getting in and out of the trailer thanks to the aluminium centre-post divider wall that can be moved to the left and right / *God plass ved inn- og utstigning takket være svingbar aluminium midtstolper/skillevegg*
- 3** Easy exit over the wide, extra-long front unloading hatch / *Enkel utstigning ved en bred og ekstra lang lasteluke foran*

- 4** The tack room in the bow offers much space for riding equipment due to its interior door and the swivelling saddle rack for English and western saddles / *Mye plass for rideutstyr ved hjelp av sadelkammeret i bunnen, med innvendig dør og svingbar sadelholder for engelsk sadel og western-sadel*
- 5** Easy access through 2 full-height, lockable entrance doors / *Enkel innstigning på grunn av 2 mannsbøye, låsbare inngangsdører*

Standard equipment.

Serieutstyret.

PORTAX L SR*	2500 kg	2815 mm	2350 mm	5355 mm	2300 mm	1750 mm	4125 mm	1261 kg	
PORTAX L SKA	2500 kg	2815 mm	2350 mm	5355 mm	2300 mm	1750 mm	4125 mm	1400 kg	
PORTAX L E	2500 kg	2815 mm	2350 mm	5355 mm	2300 mm	1750 mm	4125 mm	1400 kg	
PORTAX L K	2500 kg	2815 mm	2350 mm	5355 mm	2300 mm	1750 mm	4125 mm	1318 kg	

All rights to changes in design and equipment reserved. Weights and dimensions approximate; changes due to additional equipment possible. Vi forbeholder oss retten til å foreta konstruksjons- og utstyrsendringer. Vekt og mål er tilnærmet. De kan endre seg grunnet tillegg utstyr.

* optionally available with 4 doors
kan leveres med 4 dører som ekstrautstyr

PORTAX L SR

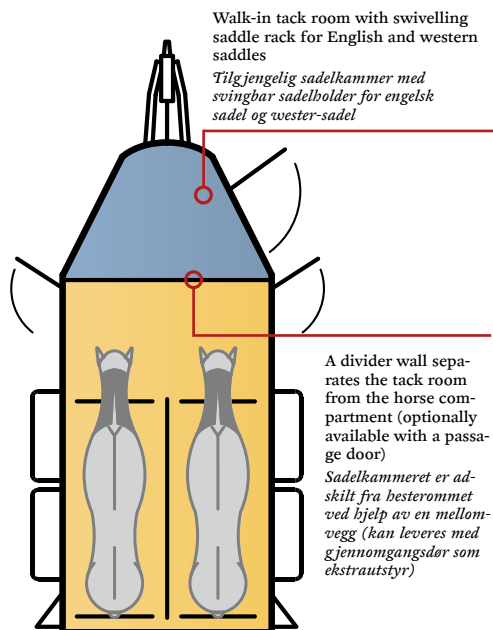

PORTAX L SKA

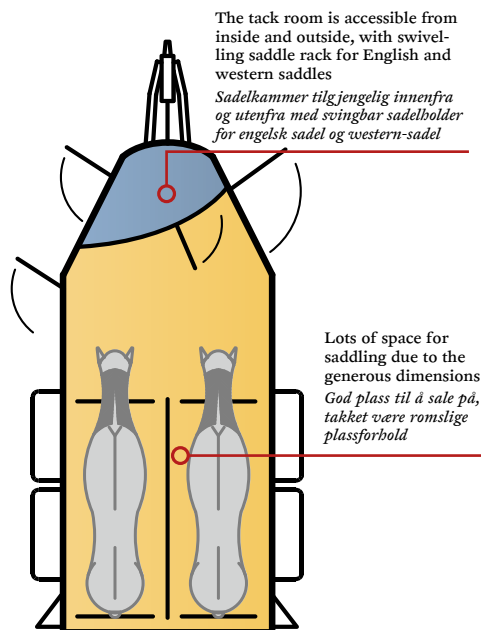

PORTAX L E

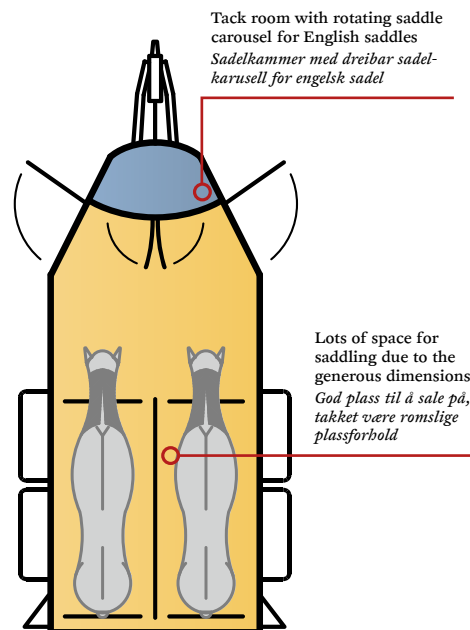

PORTAX L K

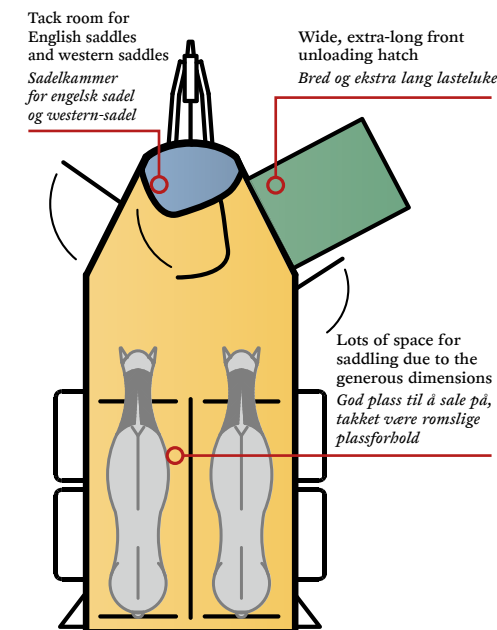

Chassis / Chassis



Even more driving comfort due to the World Class chassis to automotive standards
Enda mer kjørekomfort grunnet World-Class-chassiset laget etter bilstandard

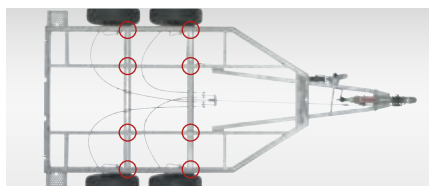

Made for heavy loads with axles bolted 8x to the longitudinal beam construction and a welded, hot-galvanised steel frame
Laget for høy belastning ved aksene som er skrudd fast til lengdedragerkonstruksjonen på 8 steder og sveisete, ildforsinkete stålrammer



Safe hitching and unhitching thanks to lockable cast coupling with padded comfort handle and soft top (drive-off protection)
Sikker til og frakobling ved hjelp av låsbare koblinger med tildekket komforthåndtak og Soft-Top (startspærre)

Additional standard features:

- Bolted v-shaped towing bar with automatic jockey wheel
- Large illumination unit with reversing light and 13-pin plug
- Generously dimensioned quality tyres
- Quality solid aluminium floor

Ytterligere serieutstyret:

- Fastskrudd v-vognstang med autom. støttehjul
- Stor belysningsenhet med ryggelys og 13-polet plugg
- Stordimensjonert kvalitetsdekk
- Kvalitets-belaluminiumsgulv

Structure / Ytre oppbygging



Broad range of applications due to the standard tail gate/1-wing door combination
Mangfoldige bruksmuligheter ved den seriemessige baklemmen/1-fløyeldørkombinasjon



Optimum interior atmosphere thanks to tarpaulin lift with integrated net** (also protects against rain and cold)
*Optimalt romklima ved hjelp av rullgardinen med integrert nett** (beskytter mot regn og kulde)*



Optimum ventilation with the sliding windows at the side, panorama windows in the polyester bow and roof vent
Skyvøvindu på siden, panoramavindu i polyesterfronten og takvifte gir et optimalt romklima

Additional standard features:

- Anodised, dual-wall aluminium structure with polyester top and bow
- Tall side walls 2100 mm
- Stainless steel 304 bolts on structure
- Impact-resistant composite mudguards
- Lifting device on rear gate
- Number plate holder with 2 integrated steps
- Decor stripes on side wall with horse head as well as horse head decor on the tail gate
- Rear strut closed
- Lockable doors with 3-point door locking system

Ytterligere serieutstyret:

- Eloksert, dobbeltvegg aluminiumsoppbygging med polyesterhette og -front
- Høy kantvegg 2100 mm
- V2A-edelståltilskruing ved oppbyggingen
- Slagfast plast-skevettlapp
- Løfteutstyr på baklemmen
- Registreringskilttholder med to integrerte trinn
- Dekorasjonsstriper med bestebode på sideveggen og bestebode-dekorasjonen på baklemmen
- Hekkbjelken er lukket
- Låsbare dører med 3-punkts-dørlås

Interior / Utstyr innvendig



The height and longitudinally adjustable safety stall bar system (panic system) Multi Safe System*** for front and rear

*Det høyde- og lengdejusterbare sikkerhetsbomsystemet (panikkssystem) Multi Safe System*** for foran og bak*



Much room for riding equipment thanks to the tack room which comes as a standard with many details for extra storage space

Mye plass på grunn av sadelkammer med mange detaljløsninger som standard



Clever utilisation of the available space due to the divider wall with folding seat and additional feeding troughs (Portax L SR, passage door in partition wall - accessory)

Allsidig romutnyttelse ved hjelp av skillevegg med utfoldbart sete og ekstra for-trau (ved Portax L SR er gjennomgangsdør i mellomveggen ekstra tilbehør)

Additional standard features:

- Transparent PVC divider, flexible with PVC top section
- Aluminium centre post partition wall that can be moved to the left and right
- Rubber matting with anti-slip structure, glued and sealed
- Rubber liner on tail gate with special cross step bars, run-off duct, and side stops
- Calming blue LED transport light with separate switch - can be switched over from white to blue

Ytterligere serieutstyret:

- Gjennomiktig PVC-skillevegg, fleksibel med PVC-overdel
- Midstolpe-skillevegg i aluminium som kan svinges mot høyre eller venstre
- Gummigulv med sklisikkert tekstilstruktur, fastlimt og forseglet
- Gummibelegg på baklemmen med spesialtverrlistor, avløpsrenne og sidestopp
- Beroligende, blått LED-transportlys med separat bryter - mulig å skifte fra hvitt til blått lys









BIG PORTAX

BIG PORTAX

 Unique design and generous space configuration: The new Big Portax with an interior width of 1850 mm and an internal height of 2400 mm provides even more space for you and your horses. The standard features include the world-class chassis “WCFplus” to automotive standard and a large tack room that is separated from the horse compartment by a partition wall with a height of 2100 mm.

 *Enestående design og storslått romdeling: Den nye Big Portax med en innvendig bredde på 1850 mm og en innvendig høyde på 2400 mm gir deg og hestene dine enda mer plass. Seriemessig har bl. a. World-Class-chassiset “WCFplus” bilstandard og et stort salkammer, som er adskilt fra hesterommet med en 2100 mm høy mellomvegg.*

At a glance / Kort oversikt

Number of horses / Antall hester	
Structure (Anodised aluminium)* Oppbygging (Eloksert aluminium)*	
	Standard: Serie: 
	Without surcharge: Uten tillegg i prisen: 
Cover and bow (Polyester)* Hette og foran (Polyester)*	
	With surcharge: Med tillegg i prisen: 
Chassis (standard) / Chassis (serie)	WCF[®] PLUS
Standard equipment / Seriestyret	Multi Safe System** MSS

Highlight of the standard equipment Hightlight blant seriestyret



Tack room equipped with many detail solutions as standard, e.g. a western saddle rack (interior door in partition wall, saddle compartment and sliding windows in side wall available as accessories)

Sadelkammer som seriemessig er utstyrt med mange detaljløsninger, som f. eks. en westernsadelholder (gjennomgangsdør i mellomveggen, sadelskap og skyvevindu i sideveggen tilbehør)

Appealing interior with flat access on a 1800 mm long tail gate, 2 separate feed troughs and 2 interior lamps on the partition wall for sufficient lighting

En flat inngang via den 1800 mm lange baklemmen, to separate førbokser og to innelykter på mellomveggen som sørger for tilstrekkelig lys gjør hengerens innerom innbydende



Complete standard equipment
Komplett seriestyret

Page 54 – 55
Side 54 – 55

Accessories
Tilbehørsprogram

Page 66 – 68
Side 66 – 68

Some illustrations do not depict standard equipment.
Illustrasjonene tilsvarende delvis ikke seriestyret.



MEGA PORTAX

 Even larger and wider: The new Mega Portax with an inside width of 2000 mm and an inside height of 2550 mm. Not only the comfort of your horses, but also the space in the generously sized tack room is a main priority. As an option the partition wall can also be equipped with a practical interior door.





 *Enda større og enda bredere: Det er den nye Mega Portax med en innvendig bredde på 2000 mm og en innvendig høyde på 2550 mm. Det er ikke bare komforten for hesten din, men også den storslåtte plassen i det romslige salkammeret som det her legges vekt på.*

Den mellomveggen kan utstyres med en praktisk gjennomgangsdør.

Appealing interior with flat access on a 1800 mm long tail gate, 2 separate feed troughs and 2 interior lamps on the partition wall for sufficient lighting
En flat inngang via den 1800 mm lange baklemmen, to separate førbokser og to innelykter på mellomveggen som sørger for tilstrekkelig lys gjør bengerens innerom innbydende



At a glance / Kort oversikt

Number of horses / Antall hester	
Structure (Anodised aluminium)* Oppbygging (Eloksert aluminium)*	
	Standard: Serie: 
	Without surcharge: Uten tillegg i prisen: 
Cover and bow (Polyester)* Hette og foran (Polyester)*	With surcharge: Med tillegg i prisen: 
Chassis (standard) / Chassis (serie)	WCF[®] PLUS
Standard equipment / Serieutstyret	Multi Safe System** MSS

Highlight of the standard equipment Highlight blant serieutstyret



Tack room equipped with many detail solutions as standard, e.g. a western saddle rack (aluminium saddle compartment available as an an accessory)

Sadelkammer som seriemessig er utstyrt med mange detaljløsninger, som f. eks. et westernsadelkammer (sadelkammerskap i aluminium tilbehør)

* More information on page 70 / Mer informasjon på side 70

** Safety stall bar system Multi Safe System / Sikkerhetsbom-systemet Multi Safe System



Complete standard equipment Komplett serieutstyret	Page 54 - 55 Side 54 - 55
Accessories Tilbehørsprogram	Page 66 - 68 Side 66 - 68

Some illustrations do not depict standard equipment.
 Illustrasjonene tilsvarer delvis ikke serieutstyret.

Standard equipment.

Serieutstyret.

BIG PORTAX	2700 kg*	2935 mm	2410 mm	5535 mm	2400 mm	1850 mm	4150 mm Tack room: 1165 mm Horse compartment: 2965 mm Salkammer: 1165 mm Hesterom: 2965 mm	1370 kg	
MEGA PORTAX	3500 kg*	3045 mm	2550 mm	5735 mm	2550 mm	2000 mm	4200 mm Tack room: 1400 mm Horse compartment: 2780 mm Salkammer: 1400 mm Hesterom: 2780 mm	1976 kg	

All rights to changes in design and equipment reserved. Weights and dimensions approximate; changes due to additional equipment possible.
Vi forbeholder oss retten til å foreta konstruksjons- og utstyrsendringer. Vekt og mål er tilnærmet. De kan endre seg grunnet tilleggsutstyret.

* Curb weight reduction possible
Reduksjon i samlet vekt mulig

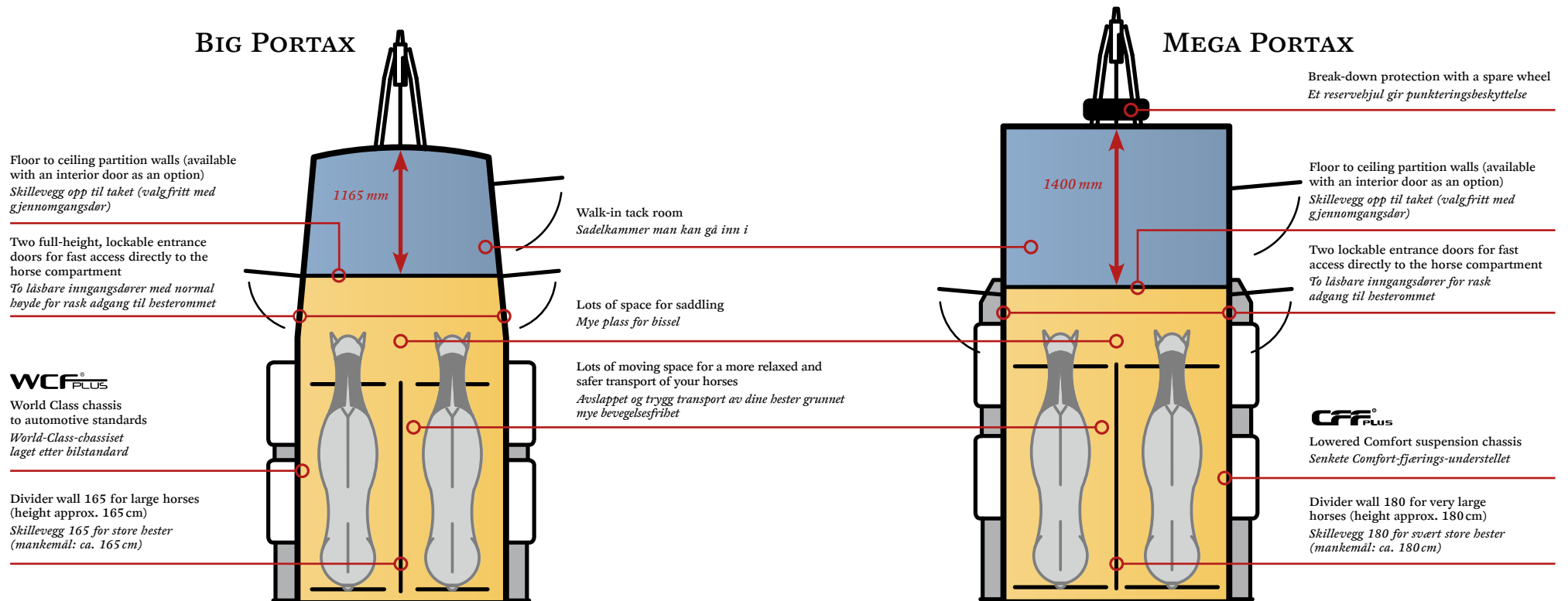

Highlight of the standard equipment Big Portax
Highlight blant serieutstyret Big Portax

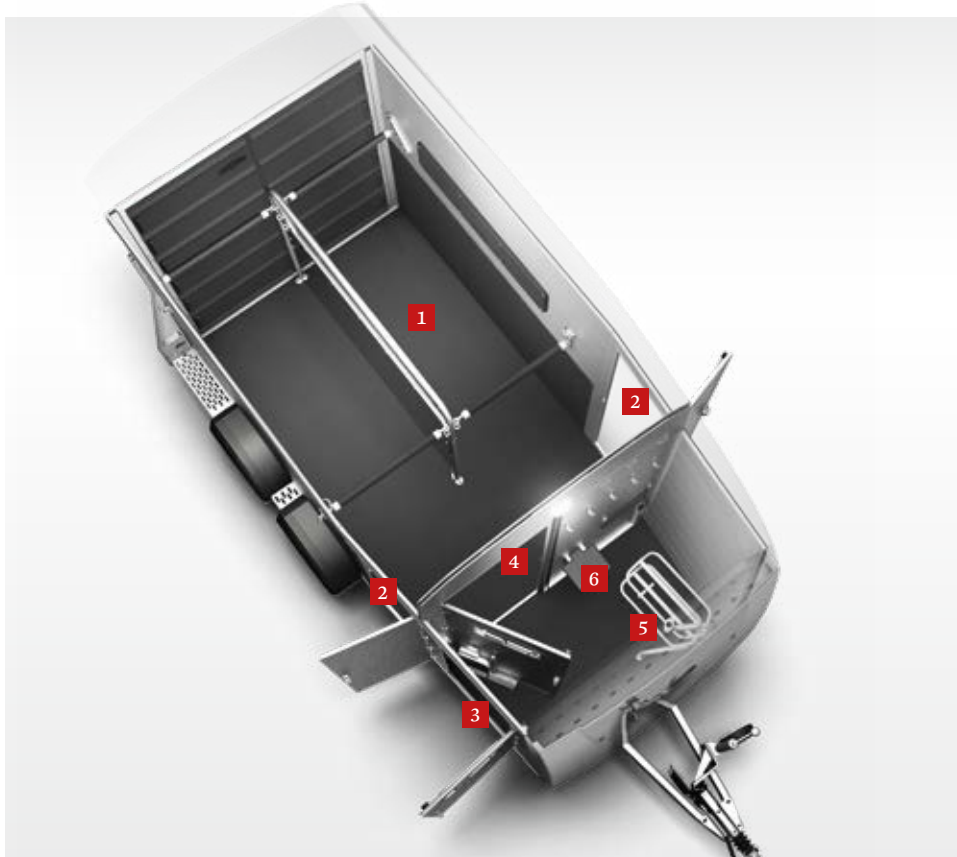

- 1** Lots of space for saddling due to the generous dimensions / *God plass til å sale på, takket være romslige plassforhold*
- 2** Easy access through full-height, lockable entrance doors / *Enkel innstigning til det tilgjengelige sadelkammeret med standard integrert skyvevindu*
- 3** Comfortable access to the walk-in tack room with integrated sliding window provided as a standard / *Enkel innstigning til det tilgjengelige sadelkammeret med standard integrert skyvevindu*

- 4** A divider wall separates the tack room from the horse compartment (optionally available with a passage door) / *Sadelkammeret er adskilt fra besterommet ved hjelp av en mellomvegg (kan leveres med gjennomgangsdør som ekstrautstyr)*
- 5** Walk-in tack room with swivelling saddle rack for English and western saddles / *Tilgjengelig sadelkammer med svingbar sadelholder for engelsk sadel og wester-sadel*
- 6** Seats / *Sittemulighet*

Highlight of the standard equipment Mega Portax
Highlight blant serieutstyret Mega Portax



Comfortable access through 3 entry doors (passage door in partition wall - accessory)
Enkel inngang via 3 inngangsdører (gjennomgangsdør i mellomveggen som tilbehør)



Much room for riding equipment thanks to the tack room which comes as a standard with many details for extra storage space
Mye plass for rideutstyr på grunn av sadelkammer med mange detaljløsninger som standard

Highlights of the Mega Portax of accessories
Highligts i Mega Portax tilbehørsprogram



With optional divider wall "Profi" for the safe transport of stallions, comprising an end-to-end aluminium divider wall (1) and an aluminium head divider section (2) on top of the divider wall.
Trygg transport ved hjelp av profesjonell hingst-skillevegg, som består av en gjennomgående aluminium skillevegg (1) og en bodeskillevegg av aluminium (2) på skilleveggen.



The robust and spacious aluminium saddle cabinets have enough room to keep all riding equipment tidied up (1 = W 1410 x H 1210 x D 680mm; 2 = W 1430 x H 1720 x D 690mm)
Alt på sin plass, takket være robust og romslig sadelskap av aluminium for rideutstyr (1 = B 1410 x H 1210 x T 680mm; 2 = B 1430 x H 1720 x T 690mm)

 **The Traveller family.**
 *Traveller-familien.*



**THE ALTERNATIVE SOLUTION:
THE TRAILER FOR THE
LATERAL THINKER.**

Simply give your horse more: More options. More space. And more loading comfort. The Traveller family is ideal for riders who would like to take several horses with them on their trips. Depending on the model, you can easily accommodate two to three large horses, three to four western horses, or up to five small horses. A powerful design with many practical details. Enjoy your trip!

**ALTERNATIVET:
HENGER FOR DE MODIGE.**

Tilbyr besten din enda mer: Flere muligheter. Mer plass. Og mer lastekomfort. Traveller-familien er ideell for alle som ønsker å transportere flere bester samtidig. Alt etter modell gir hengeren rikelig plass for to til tre store hester, tre til fire westernbester eller inntil fem mindre bester. I et kraftfullt design og med mange praktiske utstyrsdetaljer. God tur!



TRAVELLER K
For small horses
For små bester
Page 57
Side 57

TRAVELLER W
For medium-sized horses
For middels store bester
Page 58
Side 58

TRAVELLER G
For large horses
For store bester
Page 59
Side 59



Traveller K3
3170 x 2000 x 2100
(Interior Dimensions /
Indre mål)

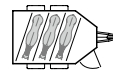

Traveller K3 BIG SK
3570 x 2000 x 2100
(Interior Dimensions /
Indre mål)

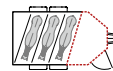

Traveller K4
3570 x 2000 x 2100
(Interior Dimensions /
Indre mål)

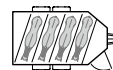

Traveller K4 BIG SK
4580 x 2000 x 2100
(Interior Dimensions /
Indre mål)



Traveller K5
4580 x 2000 x 2100
(Interior Dimensions /
Indre mål)

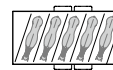

TRAVELLER K3

TRAVELLER K

🇬🇧 Specially engineered for small horses and their riders, the Traveller K impresses with its compact and versatile design. It offers ample space for up to five small horses. The impressive list of features makes handling child's play and guarantees both comfort and safety for your horse.

🇳🇴 *Utviklet spesielt for små hester og deres ryttere, overbeviser Traveller K med sin kompakte og lettstyrte byggemåte. Inntil fem mindre hester finner her rikelig plass. Det omfangrike utstyret gjør håndteringen til en lek og gir hesten din både komfort og sikkerhet.*



🇬🇧 At a glance / 🇳🇴 Kort oversikt

Number of horses Antall hester	(2 - 3) (3 - 4) (4 - 5)
Structure (Anodised aluminium)* Oppbygging (Eloksert aluminium)*	<input type="checkbox"/> Standard: <input type="checkbox"/> Serie:
Cover (Polyester)* Hette (Polyester)*	Without surcharge: Uten tillegg i prisen: <input type="checkbox"/> <input type="checkbox"/> <input type="checkbox"/> <input type="checkbox"/> With surcharge: Med tillegg i prisen: <input type="checkbox"/> <input type="checkbox"/> <input type="checkbox"/> <input type="checkbox"/>
Chassis (standard) / Chassis (serie)	<input checked="" type="checkbox"/> CFF ^{Plus}

* More information on page 70 / Mer informasjon på side 70

Highlight of the standard equipment Highlight blant seriestyret



Plenty of space for your riding equipment thanks to the spacious tack room, which is separated from the horse compartment by a swivelling aluminium divider

Det romslige salkammeret gir mye plass til rideutstyret. Salkammeret er adskilt fra hestedelen ved en mellomvegg i aluminium som kan svinges

i	Complete standard equipment Komplett seriestyret	Page 60 Side 60
	Accessories Tilbehørsprogram	Page 61 Side 61

Some illustrations do not depict standard equipment.
Illustrasjonene tilsvarende delvis ikke seriestyret.



Traveller W2 BIG SK
3570 x 2000 x 2400
(Interior Dimensions /
Indre mål)

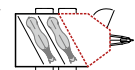

Traveller W3
3570 x 2000 x 2400
(Interior Dimensions /
Indre mål)

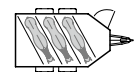

Traveller W3 BIG SK
4570 x 2000 x 2400
(Interior Dimensions /
Indre mål)

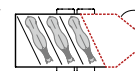

Traveller W4
4570 x 2000 x 2400
(Interior Dimensions /
Indre mål)

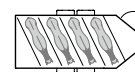

TRAVELLER W

 Whether you prefer Western horses, Arabs or polo ponies: The Traveller W guarantees a first class trip for three or even four horses. With high quality features, including a tack room, large saddle racks and a diagonal loading system. – And on top of that excellent stability thanks to the steel bar that surrounds the whole body.





 Om det gjelder westernbester, arabere eller polobester: Med Traveller W reiser tre eller til og med fire bester på første klasse. Med høyverdig utstyr inklusive salkammer, stor sadelholder og diagonalladesystem. – og i tillegg en fremragende stabilitet takket være stålbøylen som går rundt det hele.

TRAVELLER W3



PE&G HORSES, Andreas Hess

At a glance / Kort oversikt

Number of horses Antall bester	 (2 – 3)  (3 – 4)
Structure (Anodised aluminium)* Oppbygging (Eloksert aluminium)*	
Cover (Polyester)* Hette (Polyester)*	Standard: Serie:
	Without surcharge: Uten tillegg i prisen:
	With surcharge: Med tillegg i prisen:
Chassis (standard) / Chassis (serie)	

Highlight of the standard equipment Highlight blant serieutstyret



Optimum stability thanks to a diagonal loading system with laterally adjustable, aluminium divider walls and PVC panels
Optimal plassering grunnet diagonallastesystemet med aluminiumsskillevegger med PVC-forbeng



Complete standard equipment Komplett serieutstyret	Page 60 Side 60
Accessories Tilbørsprogram	Page 61 Side 61

Some illustrations do not depict standard equipment.
Illustrasjonene tilsvarer delvis ikke serieutstyret.





Traveller G2
3570 x 2000 x 2400
(Interior Dimensions /
Indre mål)

Traveller G3
4570 x 2000 x 2400
(Interior Dimensions /
Indre mål)

TRAVELLER G3



















TRAVELLER G

 The Traveller G allows you to transport two or three large horses at the same time. The G model, which is extremely robust thanks to steel bars that surround the whole body include extendable and laterally displaceable aluminium dividers with PVC panels as standard equipment.

 Med Traveller G kan du transportere to eller tre store hester på en gang. G-modellene er spesielt robuste grunnet ståløylen som går rundt det hele og de er seriemessig utstyrt med aluminiumskillevegger som er teleskoperbare og kan innstilles på siden og har PVC-forheng.



 At a glance /  Kort oversikt

Number of horses Antall hester	 - 
Structure (Anodised aluminium)* Oppbygging (Eloksert aluminium)*	
	Standard: Serie: 
	   
Cover (Polyester)* Hette (Polyester)*	Without surcharge: Uten tillegg i prisen:  
	With surcharge: Med tillegg i prisen:    
	   
Chassis (standard) / Chassis (serie)	

Highlight of the standard equipment
Highlight blant serieutstyret



Plenty of space thanks to large tack rooms with adjustable and extendable saddle racks (door in divider available as option)
Det store salkammeret med justerbar- og uttrekkbare salholdere gir mye plass (dør i skilleveggen er tilbehør)

For large horses with a height of up to approx. 165 cm
For store hester med en mankeøyde på inntil ca. 165 cm









Complete standard equipment Komplett serieutstyret	Page 60 Side 60
Accessories Tilbehørsprogram	Page 61 Side 61

Standard equipment.





Serieutstyret.





For small horses of height up to approx. 145 cm / For små hester med mankehøyde på inntil ca. 145 cm

	TRAVELLER K3	2400 kg*/2700 kg* ¹	2490 mm	2550 mm	4615 mm	2100 mm	2000 mm	3170 mm	1225 kg/1525 kg ¹	1175 kg	 (2 - 3)
	TRAVELLER K3 BIG SK	2700 kg*/3000 kg* ¹	2490 mm	2550 mm	5015 mm	2100 mm	2000 mm	3570 mm	1480 kg/1780 kg ¹	1220 kg	 (2 - 3)
	TRAVELLER K4	2700 kg*/3000 kg* ¹	2490 mm	2550 mm	5015 mm	2100 mm	2000 mm	3570 mm	1480 kg/1780 kg ¹	1220 kg	 (3 - 4)
	TRAVELLER K4 BIG SK	3500 kg*	2510 mm	2550 mm	5705 mm	2100 mm	2000 mm	4570 mm	1880 kg	1620 kg	 (3 - 4)
	TRAVELLER K5	3500 kg*	2510 mm	2550 mm	5705 mm	2100 mm	2000 mm	4570 mm	1880 kg	1620 kg	 (4 - 5)

For medium-sized horses of height up to approx. 155 cm / For middels store hester med mankehøyde på inntil ca. 155 cm

	TRAVELLER W2 BIG SK	2700 kg*	2790 mm	2550 mm	5015 mm	2400 mm	2000 mm	3570 mm	1405 kg	1295 kg	
	TRAVELLER W3	2700 kg*	2790 mm	2550 mm	5015 mm	2400 mm	2000 mm	3570 mm	1405 kg	1295 kg	 (2 - 3)
	TRAVELLER W3 BIG SK TRAVELLER 3500 kg*		2810 mm	2550 mm	5705 mm	2400 mm	2000 mm	4570 mm	1880 kg	1620 kg	 (2 - 3)
	W4	3500 kg*	2810 mm	2550 mm	5705 mm	2400 mm	2000 mm	4570 mm	1880 kg	1620 kg	 (3 - 4)

For large horses of height up to approx. 165 cm / For store hester med mankehøyde på inntil ca. 165 cm

	TRAVELLER G2	2700 kg*	2790 mm	2550 mm	5015 mm	2400 mm	2000 mm	3570 mm	1405 kg	1295 kg	
	TRAVELLER G3	3500 kg*	2810 mm	2550 mm	5705 mm	2400 mm	2000 mm	4570 mm	1830 kg	1670 kg	

All rights to changes in design and equipment reserved. Weights and dimensions approximate; changes due to additional equipment possible. * Curb weight reduction possible. ¹ Accessories. Vi forbeholder oss retten til å foreta konstruksjons- og utstyrsendringer. Vekt og mål er tilnærmet. De kan endre seg grunnet tilleggsutstyret. Reduksjon i samlet vekt mulig. Tilbehør

Chassis / Chassis

- Lowered chassis with single-wheel suspensions
- Quality solid aluminium floor
- Lockable cast coupling with padded comfort handle and soft-top (drive-off protection)
- Galvanized steel frame
- Reinforced, automatic jockey wheel
- Senket understell med hjulstøtdempere
- Kvalitets-beluminiumsgulv
- Låsbar kobling med tildekket komforthåndtak og Soft-Top (startspærre)
- Illdforsinkete stålrammer
- Forsterket automatisk støttehjul

Structure / Ytre oppbygging

- Anodised aluminium side walls
- Polyester top in silver-metallic
- Large access door on right (K), large access door on left (W/G)
- Combi-lift with tarpaulin and net (K), tarpaulin lift with integrated net** (W/G)
- Composite single-wheel mudguards
- 2 Manoeuvring handles
- 1 Tying bars left and right
- Roof vents
- Rear strut closed
- Horse head decor on tail gate
- Number plate holder with 2 integrated steps
- Traveller K: K3/K3 BIG SK/K4: 2 small side windows left and right; K4 BIG SK/K5: 4 small side windows left and 3 sliding windows right
- Traveller W/G: W2 BIG SK/W3/G2: 2 small side windows left and 2 large sliding windows right; W3 BIG SK/W4/G3: 3 small sliding windows left and 3 large sliding windows right
- Aluminium-eloiserte aluminiumsvegger
- Polyesterhette i sølv-metallic
- Stor inngangsdør til høyre (K), stor inngangsdør til venstre (W/G)
- Kombitrek med gardin og nett (K), rullgardin med integrert netti** (W/G)
- Enkelthjulskvettlapp i plast
- 2 parkeringshåndtak
- 1 festestang blv. til høyre og venstre
- Takvifter
- Hekkbjelken er lukket
- Hestebode-dekorasjon på baklemmen
- Registreringskiltbolder med to integrerte trinn
- Traveller K: K3/K3 BIG SK/K4: 2 små skyvevinduer til høyre og venstre; K4 BIG SK/K5: 4 små skyvevinduer til venstre og 3 skyvevinduer til høyre
- Traveller W/G: W2 BIG SK/W3/G2: 2 små skyvevinduer til venstre og 2 store skyvevinduer til høyre; W3 BIG SK/W4/G3: 3 store skyvevinduer til venstre og 3 store skyvevinduer til høyre

Interior / Utstyr innvendig

- Rubber flooring, adhesion bonded and sealed, rubber liner on tail gate with special cross step bars
- Side wall left and divider wall to tack room with kick protection
- Calming blue LED transport light with separate switch - can be switched over from white to blue
- Swivelling divider wall to horse compartment (K), fixed bulkhead to horse compartment (W/G)
- Large tack room with plastic shovel, telescopic brush, mirror, door net and folding saddle holder on door
- 3 saddle holders (K), 3 (W2 BIG SK/W3) or 4 (W3 BIG SK/W4) saddle holders for large saddles (W), 2 (G2) or 3 (G3) saddle holders (G)
- Gummigulv, limt og forseglet og gummibelegg på baklemmen med spesialtverrlister
- Sidevegg til venstre og mellomveggen til salkammeret er utstyrt med sparbeskyttelse
- Beroligende, blått LED-transportlys med separat bryter - mulig å skifte fra hvitt til blått lys
- Svingbar mellomvegg til besteavdelingen (K), fast mellomvegg til besteavdelingen (W/G)
- Stort salkammer med plastspade, teleskopkost, speil, dørrnett og en sadelholder som kan klappes igjen på døren
- 3 sadelholdere (K), 3 (W2 BIG SK/W3) blv. 4 (W3 BIG SK/W4) sadelholdere for store sadler (W), 2 (G2) blv. 3 (G3) salholdere (G)

🇬🇧 Accessories.



Easy exit thanks to wide, extra-long ramp with rubber liner and lifting device "gas springs" (only for Traveller G)

Enkel utgang gjennom den brede, ekstra lange utløpslemmen med gummibelegg og løfteutstyr "støtdemper" (kun for Traveller G)



Makes waiting a pleasure thanks to lateral fold-up flap with gas springs and sliding window
Vippelementene på siden med støtdemper og sidevindu gjør ventetiden behagelig

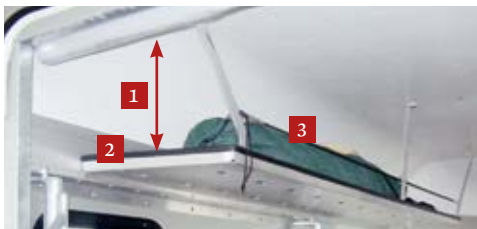

More storage options with the new overhead rack with more space to the cover (1), edge protection (2) as well as load arrester (3)

Den nye takhyllen med større avstand til betten (1), kantbeskyttelsen (2) og lastsikringen (3) gir nye lagringsmuligheter

🇳🇴 Tilbehørsprogram.



Safe transport thanks to head divider wall, e.g. for transporting stallions

Hodeskillevæggen gir sikker transport, f. eks. ved transport av to hingster



Flexible tying up arrangements thanks to Airliner bar and tying up chains

Fleksibel fiksering ved hjelp av airlinerskinne og festekjeder



Access without tail gate via double-door at rear with espagnolette locking and 2 sliding windows instead of tail gate

Inngang uten baklem gjennom dobbeltfløyet dør bak med dreiestangløs og to skyvevinduer istedenfor baklem



Sun protection thanks to extendable awning
Solbeskyttelse ved hjelp av uttrekkbar markise



Video surveillance system
Videoovervåkingsanlegg



Additional access to the tack room through a door in the divider wall to the tack room (for Traveller W and G only)

Videre tilgang til sadelkammeret via en dør i skilleveggen mot sadelkammeret (kun for Traveller W og G)

Additional accessories:

- Jacks at rear
- Additional tying up rings
- External spot left (front or rear)
- Third brake light in polyester top
- Additional roof vents on polyester top
- Exclusive Böckmann decors (designed by Jan Künster)
- Feed troughs
- Polyester mud guards (single wheel mud guards)
- Spare wheel and wheel holder
- Additional sliding windows
- Generator 230 V, 1850 Watt
- Bridle pegs
- Kick protection (composite) on right side wall (left as standard equipment)
- Wear mat
- 2 sockets 230 V in storage compartment with circuit breaker
- Additional access to the tack room through a door in the tack room divider wall (only for Traveller W and G)

Ytterligere tilbehør:

- Parkeringsstøtter bak
- Festemaljer i tillegg
- Ekstern lykt til venstre (foran eller bak)
- Tredje bremselys i polyesterbetten
- Ekstra takvifte i polyesterbetten
- Eksklusiv Böckmann dekorasjoner (designet av Jan Künster)
- Førbokser
- Polyesterskvettlapp (enkelthjulskvettlapp)
- Reserverhjul - og holder
- Skyvevindu i tillegg
- Strømgenerator (generator 230 V, 1850 Watt)
- Trinsekroker
- Sparkeplater (plast) til høyre på sideveggen (venstre seriemessig)
- Slitematte
- 2 stikkontakter 230 V i lasterommet med feilstrømbryter
- En dør i skilleveggen mot salkammeret gir ytterligere tilgang til salkammeret (kun for Traveller W og G)

🇬🇧 Original Böckmann Accessories.
🇳🇴 *Originalt Böckmann-tilbehør.*





Model types. Modellutførelser.

Duo Carriage C*

Information on Duo C >p. 24
and for Champion C >p. 29

Duo Vogn C*

Informasjon ang. Duo C > s. 24
og ang. Champion C > s. 29



BIG MASTER WESTERN

Information on Big Master >p. 36
Informasjon ang. Big Master > s. 36



DUO C WESTERN
Information on Duo C >p. 24
Informasjon ang. Duo C >s. 24



CHAMPION C WESTERN
Information on Champion C >p. 29
Informasjon ang. Champion C >s. 29



BIG CHAMPION R WESTERN
Information on Big Champion R >p. 30
Informasjon ang. Big Champion R >s. 30



COMFORT WESTERN
Information on Comfort >p. 31
Informasjon ang. Comfort >s. 31



GRAND MASTER WESTERN
Information on Grand Master >p. 37
Informasjon ang. Grand Master >s. 37



BIG MASTER L WESTERN
Information on Big Master L >p. 36
Informasjon ang. Big Master L >s. 36



PORTAX K
Information on Portax K >p. 41-43
Informasjon ang. Portax K >s. 41-43



TRAVELLER W
Information on Traveller W >p. 58
Informasjon ang. Traveller W >s. 58

Carriage / Vogn



Tack room for carriage equipment with extendable saddle racks, shovel, brush, mirror, door net and interior lighting (option)

Salkammer for vognutstyr med uttrekkbare sadelholdere, spade, kost, speil, dørrnett og en innvendig belysning (tilbehør)



Optimum load on coupling due to adjustable horse standing space depending on load state (driving with or without coach)

Optimal støttelast ved hjelp av de justerbare ståflatene til hesten som tilpasses alt etter lastetilstand (kjøring med eller uten vogn)



Carriage retainer* with covered aluminium corrugated plate and loading ramps; optionally with tube for stowing whip

Vognholder* med lukket alu-rilleplate og oppkjøringskinner, kan fås med rør for pilsken

Western / Western



Tack room with large saddle racks for Western saddles; shovel, brush, mirror, door net, saddle blanket holder and interior lighting as standard equipment

Salkammer med store sadelholdere for western-sadler; seriemessig med spade, kost, speil, dørrnett, sjabrakkstativ og innbelysning



Divider with optimised standing space dimensions for medium sized horses (height: approx. 155 cm, Big Master Western with standard divider wall T 165)
Skillevegg med optimert standmål for middels store hester (mankemål: ca. 155 cm, Big Master Western med standard-skillevegg T 165)



CHAMPION PONY C
Information on
Champion C > p. 29
Informasjon ang.
Champion C > s. 29

DUO PONY C
Information on Duo C > p. 24
Informasjon ang. Duo C > s. 24



DUO ISY C
Information on
Duo C > p. 24
Informasjon ang.
Duo C > s. 24

CHAMPION ISY C
Information on Champion C > p. 29
Informasjon ang. Champion C > s. 29

 **Pony / Ponni**



Ideal for small horses with an interior height of 2120 mm; two feed troughs ensure easily accessible feed during transportation

Ideell for små hester grunnet den indre høyden på 2120 mm; to førbokser sørger for at føret er lett tilgjengelig under kjøringen



Comfortable transport thanks to divider with standing space optimised for small horses such as riding ponies (height: approx. 145 cm)

Behagelig transport grunnet skilleveggen med optimert standmål for små hester som f. eks. rideponnier (mankemål: ca. 145 cm)

 **Iceland Ponies / Islandsbest**



Tack room with extendable saddle racks, shovel, brush, mirror, door net, saddle blanket holder and interior lighting (optional extra)

Salkammer med uttrekkbare sadelholdere, spade, kost, speil, dørrnett, sjabrakkstativ og innebelysning (tilbehør)



Divider wall with standing space optimised for Icelandic ponies (height up to approx. 145 cm); fencing systems can be stowed in the storage compartment at the side (standard equipment)

Skillevegg med optimerte standmål for islandsbest (mankemål inntil ca. 145 cm); Det finnes plass til gjerdesystemene i de seriemessige hyllene langs siden

🇬🇧 Accessories. 🇳🇴 Tilbehørsprogram.

Chassis / Chassis



Even more driving comfort with the world-class chassis to automotive standard (as standard feature on the Big Champion R, Master family, Portax and Big Portax) with wheel shock absorbers, galvanised independent wheel suspension and coil spring suspension

World-Class-chassiset med bilstandard (allerede seriøssig for Big Champion R, Master-familien, Portax og Big Portax) med hjulstøtdempere, ildforsinket enkelthjuloppbeng og skruefføring gir mer kjørekomfort



Stunning looks due to aluminium wheels
Aluminiumsfelger er en optisk highlight



Protected against dirt & damp thanks to weather-proof protective cover
Sikker mot smuss og fuktighet takket være den værbestandige beskyttelseshetten

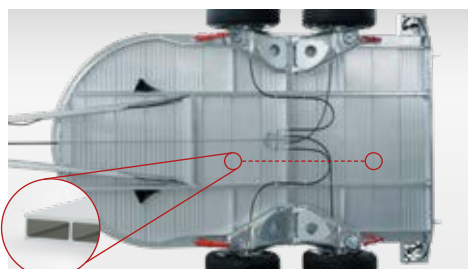

Robust and rot-proof thanks to quality solid aluminium floor (standard equipment in some cases)
Robust og råtefritt grunnet det massive kvalitets-beluminiumsgulv (delvis allerede seriøssig)

Additional accessories:

- Adapter 13-pin to 7-pin
- Curb weight increase (on request)

If you need information about further accessories, please contact your local Böckmann partner for friendly and competent advice.

Ytterligere tilbehør:

- Adapter fra 13-polet til 7-polet
- Totalvektøkning (på oppfordring)

Ta kontakt med din lokale Böckmann-partner. Han/hun gir deg gjerne råd og veiledning.

Structure / Ytre oppbygging



Practical storage options thanks to storage bar for saddle and saddle blanket (on side of trailer)
Praktisk opphengingsmulighet med en bøyle for sadel og sjabrakk (langs siden på hengeren)



Break-down protection with a spare wheel, spare wheel holder and spare wheel cover
Punkteringsbeskyttelse med et reservehjul, en reservehjulholder og et reservehjulstrekk



Safety on the road thanks to folding foal gates
Folegitteret som kan vippes gir sikker transport



Optimum interior atmosphere due to roof vent in the polyester cover
Takviften i polyesterbetten gir et optimalt romklima



Optimum interior atmosphere with side sliding windows in the polyester cover, aluminium doors or side walls
Skyvevinduene på siden i polyesterbetten, i aluminiumsdørene eller sideveggene gir optimalt romklima



Lockable polyester tail gate equipped with gas spring (except Uno, Duo Pony, Duo Isy, Portax and Traveller)
Låsbar polyester-baklem utstyrt med støtdempere (unntatt Uno, Duo Pony, Duo Isy, Portax og Traveller)

Structure / Ytre oppbygging



Increased safety in road traffic thanks to a third brake light integrated in the number plate holder

Mer sikkerhet på veien ved et tredje bremselys som er integrert i bilskiltholderen



Practical accommodation of a sulky with the sulky holder fastened to the tail gate

Man kan lett ta med sulkjene på sulkyholderen på baklemmen

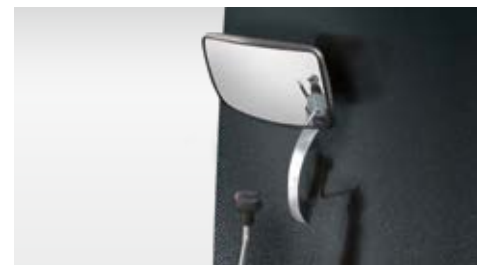

Easy coupling with practical drive-off mirror that ensures a good view of the tow hitch and aids driving off with your car

Komfortabel tilkobling takket være det praktiske startspeilet, som sørger for god sikt til clutchen og dermed gjør det lettere å starte med bilen



If you need information on further accessories, please contact your local Böckmann partner for friendly and competent advice.

Ta kontakt med din lokale Böckmann-partner. Han/hun gir gjerne råd og veiledning.



Additional second access door on the left – for wooden and aluminium models (only for models without tack room)

Andre inngangsdør til venstre for tre- og aluminiumsutførelse (kun for modeller uten salkammer)



Broad range of applications thanks to tail gate/ 1 double-door combination (not available for all models)

Mangfoldige bruksmuligheter for baklemmen/ 1-fløyelskombinasjonen (ikke tilgjengelig for alle modeller)



Visual highlight: polyester side strut covers and polyester single-wheel mudguards (standard feature on the Master family)

Sidebjelkedekeleet i polyester og enkelthjulskvettlappen f. eks. (serie for Master-familien) gjør at bengeren er flott å se på



Patented mounting step, can be easily unfolded on the tail gate (except the Traveller)

En patentert klatrehjelp er montert på baklemmen (unntatt Traveller)

Depending on the model and equipment, not all detailed solutions shown are available as standard or options. Please refer to our price list for a full catalogue of accessories. Your Böckmann Partner will be pleased to help you!
Alt etter modell og utstyr tilbører ikke alle de avbildete detaljløsningene til det seriemessige utstyret og det er ikke nødvendigvis tilgjengelig som tilbehør. Den komplette tilbehørskatalogen finner du i prislisen vår. Din Böckmann-partner gir deg gjerne råd!

Interior / Utstyr innvendig



Durable thanks to kick protection (composite) on side walls

Lang levetid grunnet sparkebeskyttelsen (plast) på sideveggene



Wear mat in front leg area – for extra durability (standard equipment in some cases)

Slitematte i området ved forbena for spesielt lang holdbarhet (delvis allerede seriemessig)



Comfortable standing position thanks to additional padding on front stable bars (standard feature with certain models)

Tilleggsopolstringene på bommen foran gir behagelig stand (delvis allerede seriemessig)



Comfortable standing position thanks to side padding (standard equipment in some cases)

Komfortabel stand grunnet sidepolstringen (delvis allerede seriemessig)



Additional interior light for sufficient light in the interior

Ekstra innvendig lykt for tilstrekkelig lys innvendig

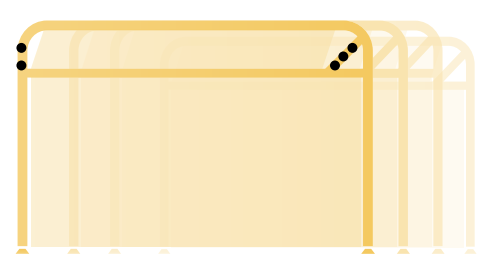

Find the right dividing wall for your horse. Additional information is provided on Page 9.

Finns den passende skilleveggen for besten din. Mer informasjon på side 9.



Aluminium head divider wall for transporting two stallions (1) or one head divider wall grating (2)

Hodeskillevegg i aluminium for transport av to hingster (1) eller en gitter-skillevegg (2)



Monitored transportation thanks to video surveillance

Videoovervåking gir kontrollert transport



Robust, spacious aluminium saddle compartments for riding equipment (1 = W 1,410 x H 1,210 x D 680 mm; 2 = W 1430 x H 1720 x D 690 mm)

Robust og romslige sadelskap i aluminium for rideutstyr (1 = B 1410 x H 1210 x D 680 mm; 2 = B 1430 x H 1720 x D 690 mm)

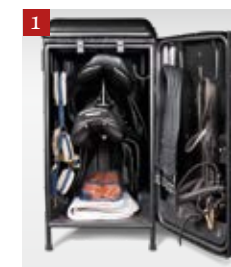

Mobile storage room with robust, mobile saddle compartments made of plastic (1) or steel plates (2)

Robuste, bevegelige sadelskap i plast (1) eller stål (2) gir mobil lagringsplass

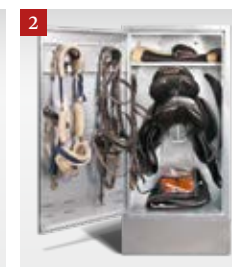

Additional accessories:

- Stable bar throughout, padded (side wall – divider, side wall – side; except Uno)
- Tack room interior made of polyester for 1-horse trailer with interior door
- Tack room interior made of polyester with 2 feed troughs for 2 horse trailer (for Champion C and Duo C models), with extendable saddle racks, shovel, brush, mirror, door net, saddle blanket holder and interior lighting as standard equipment

If you need information on further accessories, please contact your local Böckmann partner for friendly and competent advice.

Ytterligere tilbehør:

- Gjennomgående bom, polstret (sidevegg – skillevegg, sidevegg – sidevegg; unntatt Uno)
- Salkammer innvendig i polyester for henger med innvendig dør for en hest
- Salkammer innvendig i polyester med to förbokser for hengere til to hester (for Champion C og Duo C-modellene), seriemessig med uttrekkbare sadelholdere, spade, speil, dørrnett, sjabakkstativ og innebelysning

Ta kontakt med din lokale Böckmann-partner. Han/hun gir gjerne råd og veiledning.

🇬🇧 Böckmann collection.

🇩🇪 Böckmann-kolleksjonen.



Blouson waistcoat / *Blouson-vest*
"BÖCKMANN LADY"

Colour / Farge dark blue / mørk blå
Size / Størrelse XXS-2XL



Blouson waistcoat / *Blouson-vest*
"BÖCKMANN SIR"

Colour / Farge dark blue / mørk blå
Size / Størrelse S-3XL, 5XL



Sweater / *Sweatjakke*
"BÖCKMANN"

Colour / Farge dark blue / mørk blå
Size / Størrelse XXS, S-3XL, 5XL (unisex)
104



Quilted jacket / *Steppjakke*
"BÖCKMANN UNI"

Colour / Farge dark blue / mørk blå
Size / Størrelse XS-3XL, 5XL (unisex)



Polo Shirt / *Poloshirt*
"BÖCKMANN SIR"

Colour / Farge dark blue / mørk blå
Size / Størrelse S-3XL, 5-6XL, 8XL



Polo Shirt / *Poloshirt*
"BÖCKMANN LADY"

Colour / Farge dark blue / mørk blå
Size / Størrelse 152, XS-2XL



Fly Rug / *Fluedekke*
"BÖCKMANN"

Colour / Farge dark blue / mørk blå
Size / Størrelse 125 cm & 145 cm



Tether rope / *Leietau*
"BÖCKMANN"

Colour / Farge dark blue / mørk blå



Halter / *Grime*
"BÖCKMANN"

Colour / Farge dark blue / mørk blå
Size / Størrelse PON, WB



Travel Boots / *Transportgamasjer*
"BÖCKMANN"

Colour / Farge dark blue / mørk blå
Size / Størrelse WB



Saddlecloth / *Sjabrakk*
"CLASSIC LINE"

Colour / Farge dark blue, white
mark blå, hvit
Size / Størrelse VS, DR



Sweat Rug / *Svettedekke*
"BÖCKMANN"

Colour / Farge dark blue / mørk blå
Size / Størrelse 125 cm & 145 cm



Grooming Bag / *Pusseveske*
"BÖCKMANN"

Colour / Farge dark blue / mørk blå
Size / Størrelse ca. 60 x 30 x 20 cm



Baseball Cap / *Basecap*
"BÖCKMANN"

Colour / Farge dark blue / mørk blå
Size / Størrelse Single Size / Enhetsstørrelse



Backpack / *Ryggsekk*
"BÖCKMANN"

Colour / Farge dark blue / mørk blå



Guest hand towel / *Gjestehåndkle*
"BÖCKMANN"

Size / Størrelse 30x50 cm



Information on collection and ordering
Informasjon angående kolleksjon & bestilling

PHONE +49 (0) 38461 415019
FAX +49 (0) 38461 65344
E-MAIL werbung@boeckmann-buetzow.de
ONLINE www.boeckmann-buetzow.de

🇬🇧 Fantastic looks for all of our families!

🇳🇴 Fantastisk for hele familien!

Standard colours for full polyester models / Standardfarger for helpolyester-modellene



Structure silver-metallic (Standard)
Decor colour anthracite
Oppbygging sølv-metallic (Serie)
Dekorasjonsfarge antrasitt



Structure dark-blue-metallic (without surcharge)
Decor colour silver
Oppbygging mørk blå-metallic (uten tillegg i prisen)
dekorasjonsfarge sølv



Structure green-metallic (without surcharge)
Decor colour silver
Oppbygging grønn-metallic (uten tillegg i prisen)
Dekorasjonsfarge sølv



Structure anthracite-metallic (without surcharge)
Decor colour silver
Oppbygging antrasitt-metallic (uten tillegg i prisen)
Dekorasjonsfarge sølv



Structure red-metallic (without surcharge)
Decor colour silver
Oppbygging rød-metallic (uten tillegg i prisen)
Dekorasjonsfarge sølv



Structure brown-metallic (similar to RAL 7086) (without surcharge)
Decor colour silver
Oppbygging brun-metallic (ligner på RAL 7086) (uten tillegg i prisen)
Dekorasjonsfarge sølv



Structure white (similar to RAL 9010) (without surcharge)
Decor colour anthracite
Oppbygging hvit (ligner på RAL 9010) (uten tillegg i prisen)
Dekorasjonsfarge antrasitt



Structure silver-grey (similar to RAL 7001) (with surcharge)
Decor colour silver
Oppbygging sølvgrå (ligner på RAL 7001) (med tillegg i prisen)
Dekorasjonsfarge sølv



Structure slate-grey (similar to RAL 7015) (with surcharge)
Decor colour silver
Oppbygging skifergrå (ligner på RAL 7015) (med tillegg i prisen)
Dekorasjonsfarge sølv



Structure Royal blue (similar to RAL 5002) (with surcharge)
Decor colour silver
Oppbygging Kongeblå (ligner på RAL 5002) (med tillegg i prisen)
Dekorasjonsfarge sølv



Structure rapeseed yellow (similar to RAL 1021) (with surcharge)
Decor colour anthracite
Oppbygging rapsgul (ligner på RAL 1021) (med tillegg i prisen)
Dekorasjonsfarge antrasitt



Structure flame-red (not a RAL colour) (with surcharge)
Decor colour anthracite
Oppbygging ildrød (ingen RAL-farge) (med tillegg i prisen)
Dekorasjonsfarge antrasitt



Structure Magenta (similar to RAL 4010) (with surcharge)
Decor colour anthracite
Oppbygging Magenta (ligner på RAL 4010) (med tillegg i prisen)
Dekorasjonsfarge antrasitt



Structure Deep orange (similar to RAL 2011) (with surcharge)
Decor colour anthracite
Oppbygging Dyp oransje (ligner på RAL 2011) (med tillegg i prisen)
Dekorasjonsfarge antrasitt



Structure Yellow-green (similar to RAL 6018) (with surcharge)
Decor colour anthracite
Oppbygging Gul-grønn (ligner på RAL 6018) (med tillegg i prisen)
Dekorasjonsfarge antrasitt

Standard colours for plywood models Plywood-modellenes standardfarger



Poly cover silver-metallic (standard)* / Structure granite grey or anthracite / Decor colour silver
Poly.-bette sølv-metallic (serie)* / Oppbygging granittgrå eller antrasitt / Dekorasjonsfarge sølv

Standard colours for aluminium models Aluminiums-modellenes standardfarger



Poly top silver-metallic (standard)* / Structure anodised aluminium / Decor colour anthracite
Poly.-bette sølv-metallic (serie)* / Oppbygging eloksert aluminium / Dekorasjonsfarge antrasitt



All polyester elements also available and combinable in different colours.
Alle polyester-elementene kan fås i ulike farger og kombinasjoner.

🇬🇧 Great looks. 🇳🇴 Noe å se frem til.

Exclusive Böckmann decors, designed by Jan Künster / Eksklusive Böckmann dekorasjoner (designet av Jan Künster)

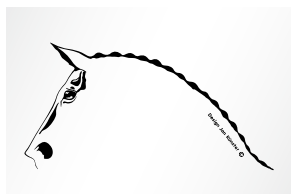

Horsehead

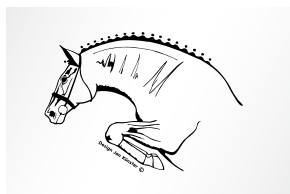

Jumping horse



Western

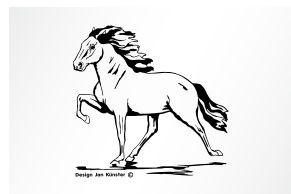

Gait horse



Arab



SMALL / LITE

Positioning example of small decor
"Jumping horse"
Plasseringseksempel for den lille
dekorasjonen på motiv "Jumping horse"



Driving

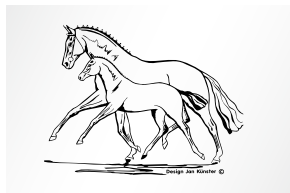

Mare with foal



Dressage



Friesian



Andalusian



Eventing

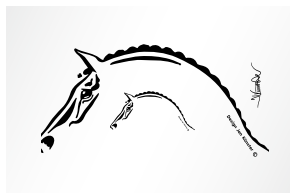

Artline



Competition



Greyscale competition



LARGE / STORT

Positioning example of large decor
motif "Riding event"
Plasseringseksempel for den store
dekorasjonen på motiv "Riding event"



Multicoloured competition



Multicoloured piaffe



Multicoloured jumper



Multicoloured strong trot



Multicoloured gallop

🇬🇧 Böckmann Horse Trucks.



www.boeckmann.com/trucks



The passion for equestrian sports has also been the driving force for us in the development of horse trucks for more than over 60 years. With absolute precision and top-notch engineering skills, we develop innovative transport solutions every day with a focus on the needs of the horse and rider. And this is exactly the philosophy we apply when designing and building our Compact (3.5–4.5 t), Performance (7.49 t) and Equipe (12–26 t) horse trucks. Every detail is individually designed and hand-crafted for you in Lastrup, Germany.

For our special catalogue, please contact us on +49 (0) 4472 895-960.

Be om å få tilsendt spesialbrosjyrer ved å ringe +49 (0) 4472 895-960.

🇳🇴 Böckmann Horse Trucks.

I mer enn 60 år har vår lidenskap for ridesport også motivert oss til å utvikle hestebusser. Daglig utvikler vi med høy presisjon og stor ingeniørkunst, nyskapende transportløsninger som setter best og rytter i sentrum. Med disse kravene som utgangspunkt, utvikler og bygger vi hestebussene Compact (3,5–4,5 t), Performance (7,49 t) og Equipe (12–26 t). Alle detaljene utformes individuelt for deg, og lages for hånd i Lastrup.



We equip your Horse Truck with tailor-made details, such as a practical bay system – after all, there is room to spare. Vi utstyres din Horse Truck med spesialtilpassete detaljer, som f. eks. et praktisk karnappsystem. Det er nok plass til det.



Comfort for all travellers: If you take a trip in a Böckmann Horse Truck, you will be relaxed when you reach your destination. And that applies not only to driver and passenger but also to the best horses on the yard.

Komfort for alle reisende: Den som reiser med en Böckmann Horse Truck kommer avslappet frem til reisemålet. Det gjelder både for sjåføren, passasjerer og for hestene dine.



Individual solutions. When we build a truck our main aim is to meet your personal requirements: from the planning process to the designing of the interior and the implementation of the concepts.

Individuelle løsninger. Ved bygging av en lastebil orienterer vi oss etter en ting: Dine personlige ønsker. Fra planleggingen, via konsepsjonen av vognens indre til realiseringen.



The entire product range on show at the Böckmann Truck Center. Prepare to marvel – then try it out: The Böckmann Truck Center showcases truck superstructures for horses on an exhibition site that extends over an area of more than 3000 m². This exhibition is unique in Germany and features the entire Böckmann product range (from 3.5 to 26 tonne trucks) as well as a number of show apartments.

Hele produktspekteret i Böckmann Truck Center: La deg først imponere, deretter kan du prøve: I Böckmann Truck Center kan du på en flate på 3000 m² innhente informasjon angående hestebengere for lastebiler. På denne utstillingen som er enestående i Tyskland kan du se hele Böckmanns produktutvalg (fra 3,5 til 26-tonns kjøretøyer) og i tillegg presenteres det en rekke innredningseksempler.

🇬🇧 Böckmann Professional Trailers.



FIRST CLASS TRANSPORT

www.boeckmann.com

This state-of-the-art series of professional trailers impresses with best in class functionality and excellent value for money. From box trailers to vehicle transporters. And from tipping trailers to platform trailers.

Den moderne serien med proffhengere utmerker seg med høyeste funksjonalitet og et utmerket pris-/ytelsesforhold. Fra kassebenger til kjøretøystransporter. Og fra vipper til cargo-laster.

🇳🇴 Böckmann proffhengere.



- 1 Van Trailers / *Koffertbenger*
- 2 Box Trailers / *Kassebenger*
- 3 Tipping Trailers / *Vipper*
- 4 Platform Trailers / *Cargo-laster*



For our special catalogue, please contact us on +49 (0)4472 895-0. Be om å få tilsendt spesialbrosjyrer ved å ringe +49 (0)4472 895-0.

🇬🇧 Böckmann Horses.



www.boeckmann-horses.com

Horse-friendly stabling with individual care and attention, foaling services, successful dressage and show jumping training and the award winning breeding stallions – top sires with a string of internationally acclaimed offspring. – Everything for the horse. Everything on one yard!

Riktig oppdrett med individuell pleie, felling, vellykket utdanning innen dressur og sprangridning og den mest dekorerte hingstestallen, med topphingster og mange internasjonale oppdretts-suksesser. – Alt for hesten. Alt på et sted!



YouTube

🇳🇴 Böckmann hester.



- 1 Stallions & Breeding / *Hingster & Oppdrett*
- 2 Sport & Training / *Sport & Trening*
- 3 Pension / *Pensjon*



For our yard brochure, please contact us on +49 (0)4472 8449. Be om å få tilsendt stall-katalogen ved å ringe +49 (0)4472 8449.



**VISIT
OUR** First equestrian
SHOW PARC

Equestrian Engineering at its Best



Röwer & Rüb
PFERDESORTSYSTEME

www.roewer-rueb.de Telefon +49 42 04- 91 40 0



Jan Künster

pure passion
pure style
pure ART
Jan Künster



www.jan-kuenster.com



WALDHAUSEN

DIE GANZE WELT DES REITSPORTS



X-LINE



S-LINE



NEED QUALITY? FIND GHI!



TOP
CONTACTS

TOP
BRANDS

TOP
PRODUCTS



Röwer & Rüb
EQUESTRIAN EQUIPMENT

PEER & SPAN
Bedding for Winners



BÖCKMANN
ANHANG ERSTER KLASSE

equitent
space for horses



GGT
EQUINE COLIC COLIC
FOOTING

BSW
Regupol®



NORKA
AUFWARTUNG
WIR DENKEN LICHT NEU.

Summerwind

SOMMER

www.germanhorseindustry.com

Your local Böckmann Partner looks forward to meeting you:
Velkommen til den lokale Böckmann forhandler:

2/2019



FIRST CLASS TRANSPORT